

Flanges and their joints
 Circular flanges for pipes, valves, fittings and accessories
 Part 1: Steel flanges, PN designated
 English version of DIN EN 1092-1

DIN
EN 1092-1

ICS 23.040.60

Supersedes DIN 2513, May 1966 edition, DIN 2514, March 1975 edition, DIN 2519, August 1966 edition, DIN 2527, April 1972 edition, DIN 2543 to DIN 2545, September 1977 editions, DIN 2546, November 1969 edition, DIN 2547, September 1977 edition, DIN 2566, DIN 2573, DIN 2576, DIN 2630 to DIN 2637, DIN 2641, DIN 2642, DIN 2655, and DIN 2656, March 1975 editions, and DIN 2673, August 1962 edition.

Flansche und ihre Verbindungen – Runde Flansche für Rohre, Armaturen, Formstücke und Zubehörteile – Teil 1: Stahlflansche, nach PN bezeichnet

European Standard EN 1092-1 : 2001 has the status of a DIN Standard.

A comma is used as the decimal marker.

National foreword

This standard has been prepared by CEN/TC 74 'Flanges and their joints' (Secretariat: Germany).

The responsible German body involved in its preparation was the *Normenausschuss Rohrleitungen und Dampfkesselanlagen* (Pipelines and Pressure Vessels Standards Committee), Technical Committee *Flansche und ihre Verbindungen*.

It should be noted that this standard does not cover all flange sizes covered by the above DIN Standards. For flange dimensions not specified here, refer to DIN 2501-1.

Amendments

The DIN Standards listed above have been fully or partially superseded by the specifications of EN 1092-1.

Previous editions

DIN 2513: 1927-01, 1936-08, 1949-06, 1966-05
 DIN 2514: 1927-01, 1929-07, 1949-06, 1967-06, 1975-03
 DIN 2519: 1964-01, 1966-08
 DIN 2527: 1963-09, 1969-03, 1971-11, 1972-04
 DIN 2543: 1926-07, 1943-05, 1949-12, 1968-01, 1977-09
 DIN 2544: 1926-07, 1943-05, 1949x-12, 1968-01, 1977-09
 DIN 2545: 1926-07, 1943-05, 1949-12, 1968-01, 1977-09
 DIN 2546: 1928-07, 1947-06, 1949x-12, 1969-04, 1969-11
 DIN 2547: 1928-07, 1947-06, 1949-12, 1969-04, 1977-09
 DIN 2566: 1926-07, 1936-08, 1943-11, 1949-06, 1962-01, 1975-03
 DIN 2573: 1940-10, 1949-05, 1962-01, 1975-03
 DIN 2576: 1963x-12, 1975-03

Continued pages 2 to 5.
 EN comprises 69 pages.

DIN 2630: 1928-04, 1949-10, 1943-11, 1949-05, 1954-12, 1962-08, 1966-08, 1975-03
 DIN 2631: 1928-04, 1936-10, 1943-11, 1949-05, 1954-12, 1962-08, 1966-08, 1975-03
 DIN 2632: 1926-10, 1931-04, 1936-08, 1943-11, 1949-05, 1954-12, 1962x-08, 1966-08, 1975-03
 DIN 2633: 1936-08, 1943-11, 1949-05, 1962-08, 1966-08, 1975-03
 DIN 2634: 1936-08, 1943-11, 1949-05, 1962-08, 1966-08, 1975-03
 DIN 2635: 1936-08, 1943-11, 1949-05, 1962x-08, 1966-08, 1975-03
 DIN 2636: 1936-08, 1947-08, 1949x-12, 1962-08, 1962-12, 1975-03
 DIN 2637: 1936-08, 1947-08, 1949-12, 1962-08, 1962-12, 1975-03
 DIN 2641: 1926-07, 1928-10, 1949-06, 1962-01, 1975-03
 DIN 2642: 1926-07, 1928-10, 1941-04, 1949-06, 1962-01, 1969-05, 1970-08, 1975-03
 DIN 2652: 1927-10, 1949-06, 1962-01
 DIN 2653: 1927-10, 1931-04, 1940-02, 1949-06, 1962-01
 DIN 2655: 1928-10, 1949-06, 1962-01, 1975-03
 DIN 2656: 1928-10, 1949-06, 1962-01, 1975-03
 DIN 2673: 1928-10, 1931-04, 1940-09, 1949-06, 1962-08
 DIN 3156: 1935x-11
 DIN 86031: 1952-04
 DIN 86043: 1952-04
 DIN HNA FI 31: 1923-08

National Annex NA

(informative)

National addendum to DIN EN 1092-1

NA.1 Correlation of flange sizes

Table NA.1 correlates the flange sizes covered by the withdrawn DIN Standards with those included in DIN EN 1092-1.

Table NA.1: Correlation of sizes

DIN Standard	Flange type as in DIN EN 1092-1	Item	Size as in DIN Standard	Size as in DIN EN 1092-1
2512	–	Tongue and groove	Up to PN 160 DN 4 to DN 1000	Up to PN 100 DN 10 to DN 2000
2513	–	Spigot and recess	DN 10 to DN 1000	Up to PN 100 DN 10 to DN 2000
2514	–	Spigot with groove and recess	DN 10 to DN 3000	Up to PN 100 DN 10 to DN 2000
2527	05	Blank flanges, PN 2,5	Not specified.	DN 10 to DN 2000
		Blank flanges, PN 6	DN 10 to DN 500	DN 10 to DN 2000
		Blank flanges, PN 10	DN 10 to DN 500	DN 10 to DN 1200
		Blank flanges, PN 16	DN 10 to DN 500	DN 10 to DN 1200
		Blank flanges, PN 25	DN 10 to DN 500	DN 10 to DN 600
		Blank flanges, PN 40	DN 10 to DN 500	DN 10 to DN 600
		Blank flanges, PN 64 (now PN 63)	DN 10 to DN 400	DN 10 to DN 400
		Blank flanges, PN 100	DN 10 to DN 350	DN 10 to DN 350
2543	–	Cast steel flanges, PN 16	DN 10 to DN 2200	DN 10 to DN 2000
2544	–	Cast steel flanges, PN 25	DN 10 to DN 2000	DN 10 to DN 2000
2545	–	Cast steel flanges, PN 40	DN 10 to DN 1600	DN 10 to DN 600
2546	–	Cast steel flanges, PN 64 (now PN 63)	DN 10 to DN 1200	DN 10 to DN 1200
2547	–	Cast steel flanges, PN 100	DN 125 to DN 700	DN 10 to DN 500

(continued)

Table NA.1 (concluded)

DIN Standard	Flange type as in DIN EN 1092-1	Item	Size as in DIN Standard	Size as in DIN EN 1092-1
2566	13	Hubbed threaded flanges, PN 10 to PN 16	DN 6 to DN 100	DN 10 to DN 600
2573	1	Plate flanges for brazing or welding, PN 6	DN 10 to DN 500	DN 10 to DN 600
2576	1	Plate flanges for brazing or welding, PN 10	DN 10 to DN 500	DN 10 to DN 600
2630	11	Weld-neck flanges, PN 1 and PN 2,5	DN 10 to DN 4 000	DN 10 to DN 4 000
2631	11	Weld-neck flanges, PN 6	DN 10 to DN 3 600	DN 10 to DN 3 600
2632	11	Weld-neck flanges, PN 10	DN 10 to DN 3 000	DN 10 to DN 3 000
2633	11	Weld-neck flanges, PN 16	DN 10 to DN 2 000	DN 10 to DN 2 000
2634	11	Weld-neck flanges, PN 25	DN 10 to DN 1 000	DN 10 to DN 1 000
2635	11	Weld-neck flanges, PN 40	DN 10 to DN 500	DN 10 to DN 600
2636	11	Weld-neck flanges, PN 64 (now PN 63)	DN 10 to DN 400	DN 10 to DN 400
2637	11	Weld-neck flanges, PN 100	DN 10 to DN 350	DN 10 to DN 350
2641	02, 33, 32	Loose plate flanges, lapped pipe ends, weld-on plate collars, PN 6	DN 10 to DN 1 200	DN 10 to DN 600
2642	02, 33, 32	Loose plate flanges, lapped pipe ends, weld-on plate collars, PN 10	DN 10 to DN 800	DN 10 to DN 600
2655	02, 33, 32	Loose plate flanges, weld-on plate collars, PN 25	DN 10 to DN 500	DN 10 to DN 600
2656	02, 33, 32	Loose plate flanges, weld-on plate collars, PN 40	DN 10 to DN 400	DN 10 to DN 600
2673	04, 34	Loose plate flanges with weld-neck collar, PN 10	DN 10 to DN 1 200	DN 10 to DN 600

NA.2 Manufacturing processes

Table NA.2 gives details of manufacturing processes.

Table NA.2: Manufacturing processes

Flange type as in DIN EN 1092-1	Forged	Rolled, seamless ^{1), 2)}	Pressed ^{1), 2)}	Made from plate	Bent and welded sections, bars or strip ¹⁾
01 (Plate flanges for welding)	Yes	Yes	Yes	Yes	Yes
02 (Loose plate flanges with weld-on plate collar)	Yes	Yes	Yes	Yes	Yes
04 (Loose plate flanges with weld-neck collar)	Yes	Yes	Yes	Yes	Yes
05 (Blank flanges)	Yes	No	Yes	Yes	No
11 (Weld-neck flanges)	Yes	Yes	Yes	No	*)
12 (Hubbed slip-on flanges for welding)	Yes	Yes	Yes	No	No
13 (Hubbed threaded flanges)	Yes	Yes	Yes	No	No
21 (Integral flanges)	Yes	Yes	Yes	No	No
32 (Weld-on plate collars)	Yes	Yes	Yes	Yes	Yes
33 (Lapped pipe ends)	Yes	Yes	Yes	Yes	Yes
34 (Weld-neck collars)	Yes	Yes	Yes	Yes	Yes

¹⁾ Manufacturing method also permitted.

²⁾ To be agreed when ordering.

*) Only for sizes from DN 700.

NA.3 Surface finish

Table NA.3 gives details of surface finish. The R_a and R_z values apply only for the as delivered condition, unless otherwise agreed at the time of ordering.

Table NA.3: Surface finish

R_a and R_z are maximum values, in micrometres.

Flange type as in DIN EN 1092-1	Outer rim		Bore		Facing	Bolt holes	Spot facing
	R_a	R_z	R_a	R_z			
01 (Plate flanges for welding)	25	160	25	160	2)	3)	4)
02 (Loose plate flanges with weld-on plate collar)	25	160	25	160			
04 (Loose plate flanges with weld-neck collar)	25	160	25	160			
05 (Blank flanges)	25	160	Without bore				
11 (Weld-neck flanges)	25 ¹⁾	160 ¹⁾	25 ¹⁾	160 ¹⁾			
12 (Hubbed slip-on flanges for welding)	25 ¹⁾	160 ¹⁾	25 ¹⁾	160 ¹⁾			
13 (Hubbed threaded flanges)	25 ¹⁾	160 ¹⁾	–				
21 (Integral flanges)	25 ¹⁾	160 ¹⁾	25 ¹⁾	160 ¹⁾			
32 (Weld-on plate collars)	25	160	25	160			
33 (Lapped pipe ends)	25	160	25	160			
34 (Weld-neck collars)	25 ¹⁾	160 ¹⁾	25 ¹⁾	160 ¹⁾			

1) Rated for pressures up to 40 bar, unmachined.
 2) As in DIN EN 1092-1, subclause 5.7.
 3) For pressures up to 40 bar, punched or drilled. For higher pressures, drilled only.
 4) As in DIN EN 1092-1, subclause 5.8.

NA.4 Designation of flange facing types

Table NA.4 correlates the old flange facing type designations used in DIN Standards with the new designations used in DIN EN 1092-1.

Table NA.4: Correlation of flange facing type designations

Old designation as in DIN Standards	New designation as in DIN EN 1092-1
Type A	Type A
Type B	
Type C	Type B 1
Type D	
Type E	Type B 2
Type F	Type C
Type N	Type D
Type V 13	Type E
Type R 13	Type F
Type V14	Type H
Type R 14	Type G

NA.5 Gaskets

Since gaskets for type H flange facings have been left unspecified in European Standards, sealing rings complying with DIN 2693 may be used.

NA.6 Lenticular ring joint gaskets

Flanges may be supplied with facings to fit lenticular ring joint gaskets as in DIN 2696, this being subject to agreement at the time of ordering.

NA.7 Diaphragm weld seals

Flanges may be supplied with a reduced flange facing diameter, d_4 , as in DIN 2695, this being subject to agreement at the time of ordering.

ZIZI ENGINEERING CO LTD

English version

Flanges and their joints

Circular flanges for pipes, valves, fittings and accessories

Part 1: Steel flanges, PN designated

Brides et leurs assemblages – Brides
circulaires pour tubes, appareils de
robinetterie, raccords et accessoires –
Partie 1: Brides en acier désignées PN

Flansche und ihre Verbindungen –
Runde Flansche für Rohre, Armaturen,
Formstücke und Zubehörteile – Teil 1:
Stahlflansche, nach PN bezeichnet

This European Standard was approved by CEN on 2001-07-06.

CEN members are bound to comply with the CEN/CENELEC Internal Regulations which stipulate the conditions for giving this European Standard the status of a national standard without any alteration.

Up-to-date lists and bibliographical references concerning such national standards may be obtained on application to the Management Centre or to any CEN member.

The European Standards exist in three official versions (English, French, German). A version in any other language made by translation under the responsibility of a CEN member into its own language and notified to the Management Centre has the same status as the official versions.

CEN members are the national standards bodies of Austria, Belgium, the Czech Republic, Denmark, Finland, France, Germany, Greece, Iceland, Ireland, Italy, Luxembourg, the Netherlands, Norway, Portugal, Spain, Sweden, Switzerland, and the United Kingdom.

CEN

European Committee for Standardization
Comité Européen de Normalisation
Europäisches Komitee für Normung

Management Centre: rue de Stassart 36, B-1050 Brussels

Contents

	Page
Foreword	3
Introduction	4
1 Scope	4
2 Normative references	5
3 Terms and definitions	7
3.1 DN	7
3.2 PN	7
3.3 maximum allowable pressure, PS	7
3.4 maximum allowable temperature, TS	7
4 Designation	7
5 General requirements	8
5.1 Flange materials	8
5.2 Repairs	9
5.3 Bolting	9
5.4 Gaskets	9
5.5 Pressure/temperature (p/T) ratings	9
5.6 Dimensions	10
5.7 Flange facings	11
5.8 Spot facing or back facing of flanges	12
5.9 Tolerances	12
5.10 Marking	12
Annex A (normative) Butt weld-end preparation	53
Annex B (informative) Material groups	54
Annex C (informative) Approximate masses of flanges and collars	56
Annex D (informative) Additional materials	64
Annex E (informative) Determination of p/T ratings for flanges using EN materials	64
Annex F (informative) Determination of p/T ratings for flanges using ASTM materials	65
Annex ZA (informative) Clauses of this European Standard addressing essential requirements or other provisions of EU Directives	67
Bibliography	69

Foreword

This document (EN 1092-1;2001) has been prepared by Technical Committee CEN/TC 74 "Flanges and their joints", the secretariat of which is held by DIN.

This European Standard shall be given the status of a national standard, either by publication of an identical text or by endorsement, at the latest by June 2002, and conflicting national standards shall be withdrawn at the latest by June 2002.

This document has been prepared under a mandate given to CEN by the European Commission and the European Free Trade Association, and supports essential requirements of EU Directive(s).

For relationship with EU Directive(s), see informative Annex ZA, which is an integral part of this document.

According to the CEN/CENELEC Internal Regulations, the national standards organizations of the following countries are bound to implement this European Standard : Austria, Belgium, Czech Republic, Denmark, Finland, France, Germany, Greece, Iceland, Ireland, Italy, Luxembourg, Netherlands, Norway, Portugal, Spain, Sweden, Switzerland and the United Kingdom.

EN 1092 consists of the following four parts:

Part 1: Steel flanges;

Part 2: Cast iron flanges;

Part 3: Copper alloy flanges;

Part 4: Aluminium alloy flanges.

This standard includes one normative and eight informative annexes.

ZIZI ENGINEERING CO LTD

Introduction

When Technical Committee, CEN/TC 74, commenced its work of producing this European Standard it took as its basis, the International standard, ISO 7005-1, Steel flanges.

In taking this decision, CEN/TC 74, agreed that this standard would differ significantly from the ISO standard in respect of the following:

- a) Whereas ISO 7005-1 included in its scope both the original DIN based flanges and also the original ANSI/ASME based flanges, EN 1092-1 contains only the DIN based flanges. CEN/TC 74 has produced a separate series of standards, prEN 1759-1:2000, prEN 1759-3:1994 and prEN 1759-4:1997, dealing with the ANSI/ASME based flanges in their original Class designations;
- b) The opportunity was taken to revise some of the technical requirements applicable to the DIN origin flanges.

Consequently, whilst the mating dimensions, the flange and facing types and designations are compatible with those given in ISO 7005-1, it is important to take account of the following differences which exist in EN 1092-1:

- 1) The p/T ratings of this standard have been reduced in many cases by either limiting the lower temperature ratings which can no longer exceed the PN value, or by increasing the rate at which allowable pressures shall reduce with increase in temperature;
- 2) In addition to the range of PN 2,5 to PN 40 DIN origin flanges contained in the ISO standard, EN 1092-1 also includes PN 63 and PN 100 flanges;
- 3) This standard specifies grades of European steels similar to those specified in ISO 7005-1, but in addition permits the use of those grades of ASTM steels which are specified in the ISO standard for use with the ANSI/ASME based flanges;
- 4) This standard gives an informative annex concerning requirements of EU Directives.

1 Scope

This European Standard for a single series of flanges specifies requirements for circular steel flanges in PN designations PN 2,5 to PN 100 and nominal sizes from DN 10 to DN 4000.

This standard specifies the flange types and their facings, dimensions, tolerances, threading, bolt sizes, flange jointing face surface finish, marking, materials, pressure/ temperature ratings and approximate flange masses.

This standard does not apply to flanges made from bar stock by turning, or to flanges of types 11, 12 and 13 made from plate material.

2 Normative references

This European Standard incorporates by dated or undated reference provisions from other publications. These normative references are cited at the appropriate places in the text and the publications are listed hereafter. For dated references, subsequent amendments to or revisions of any of these publications apply to this European Standard only when incorporated in it by amendment or revision. For undated references the latest edition of the publication referred to applies (including amendments).

EN 764, *Pressure equipment - Terminology and symbols - Pressure, temperature, volume*

EN 1333, *Pipework components - Definition and selection of PN*

EN 1708-1, *Welding - Basic weld joint details in steel - Part 1: Pressurized components*

EN 10025, *Hot rolled products of non-alloy structural steels - Technical delivery conditions*

prEN 10028-2:2000, *Flat products made of steels for pressure purposes - Part 2: Non alloy and alloy steels with specified elevated temperature properties*

prEN 10028-3:2000, *Flat products made of steels for pressure purposes - Part 3: Weldable fine grade steels, normalised*

prEN 10028-4:2000, *Flat products made of steels for pressure purposes - Part 4: Nickel alloy steels with specified low temperature properties*

EN 10028-7, *Flat products made of steels for pressure purposes - Part 7: Stainless steels*

EN 10213-2, *Technical delivery conditions for steel castings for pressure purposes - Part 2: Steel grades for use at room temperature and elevated temperatures*

EN 10213-3, *Technical delivery conditions for steel castings for pressure purposes - Part 3: Steel grades for use at low temperatures*

EN 10213-4, *Technical delivery conditions for steel castings for pressure purposes - Part 4: Austenitic and austenitic-ferritic steel grades*

EN 10222-2, *Steel forgings for pressure purposes - Part 2: Ferritic and martensitic steels with specified elevated temperature properties*

EN 10222-3, *Steel forgings for pressure purposes - Part 3: Nickel steel with specified low temperature properties*

EN 10222-4, *Steel forgings for pressure purposes - Part 4: Weldable fine grain steels with high proof strength*

EN 10222-5, *Steel forgings for pressure purposes - Part 5: Austenitic, martensitic and austenitic-ferritic stainless steels*

prEN ISO 9692-1:2000, *Welding and allied processes - Recommendation for joint preparation - Part 1: Manual metal-arc welding, gas-shielded metal-arc welding and gas welding of steels (ISO/DIS 9692-1:2000)*

EN ISO 9692-2, *Welding and allied processes - Joint preparation - Part 2: Submerged arc welding of steels (ISO 9692-2:1998)*

EN ISO 6708, *Pipe components - Definition of DN (nominal size) (ISO 6708:1995)*

ISO 7-1, *Pipe threads where pressure-tight joints are made on the threads – Part 1: Dimensions, tolerances and designation*

ISO 7-2, *Pipe threads where pressure tight joints are made on the threads – Part 2: Verification by means of limit gauges*

ISO 887, *Plain washers for metric bolts, screws and nuts - General plan*

ASTM A105/A105M, *Forgings, Carbon Steel, for Piping Components*

ASTM A182/A 182M, *Forged or Rolled Alloy-Steel Pipe Flanges, Forged Fittings, and Valves and Parts for High-Temperature Service*

ASTM A203/A203M, *Pressure Vessel Plates, Alloy Steel, Nickel*

ASTM A204/A204M, *Specification for pressure vessel plates, alloy steel, molybdenum*

ASTM A216/A216M, *Steel Castings, Carbon Suitable for Fusion Welding for High-Temperature Service*

ASTM A217/A217M, *Steel Castings, Martensitic Stainless and Alloy, for Pressure-Containing Parts Suitable for High-Temperature Service*

ASTM A240/A240M, *Heat-Resisting Chromium and Chromium-Nickel Stainless Steel Plate, Sheet, and Strip for Pressure Vessels*

ASTM A325, *High-Strength Bolts for Structural Steel Joints*

ASTM A350/A350M, *Forgings, Carbon and Low-Alloy Steel, Requiring Notch Toughness Testing for Piping Components*

ASTM A351/A351M, *Castings, Austenitic, Austenitic-Ferritic (Duplex) for Pressure-Containing Parts*

ASTM A352/A352M, *Steel Castings, Ferritic and Martensitic, for Pressure-Containing Parts Suitable for Low-Temperature Service*

ASTM A387/A387M, *Pressure Vessel Plates, Alloy Steel, Chromium-Molybdenum*

ASTM A515/A515M, *Pressure Vessel Plates, Carbon Steel, for Intermediate and Higher-Temperature Service*

ASTM A516/A516M, *Pressure Vessel Plates, Carbon Steel, for Moderate and Lower-Temperature Service*

ASTM A537/A537M, *Pressure Vessel Plates, Heat-Treated, Carbon-Manganese-Silicon Steel*

3 Terms and definitions

For the purposes of this standard the following terms and definitions apply:

3.1

DN

see EN ISO 6708

3.2

PN

see EN 1333

3.3

maximum allowable pressure, PS

means the maximum pressure for which the equipment is designed, as specified by the equipment manufacturer

3.4

maximum allowable temperature, TS

means the maximum temperature for which the equipment is designed, as specified by the equipment manufacturer

4 Designation

4.1 General

Table 1 specifies the flange types and ancillary components.

Figures 1 and 2 show flange types and ancillary components with the relevant flange type numbers. Flanges shall be denoted with "flange type" and the "flange number". Ancillary components shall be denoted with ancillary component type and the type number.

Figure 3 shows flange facing types, which may be used with the flanges or components shown in figures 1 and 2. Flange facings shall be denoted with "type" and the relevant symbol.

The range of DN, applicable to each flange type and to each PN, shall be as given in table 3.

4.2 Standard designation

Flanges and ancillary components in accordance with this standard shall be designated with the following:

- a) Designation, e.g. flange, lapped end or collar;
- b) Number of this standard, EN 1092-1;
- c) Number of flange type in accordance with figures 1 and 2;
- d) Type of flange facing in accordance with figure 3;
- e) DN (nominal size);
- f) PN designation;
- g) Neck thickness S (only for types 11 and 34);
- h) For type 13 flanges type of thread (R_p or R_c);
- i) Bore diameter (for sizes greater than DN 600);

B_1 (only for types 01, 12 and 32);

B_2 (only for type 02);

B_3 (only for type 04);

- j) Either the symbol or the number or the grade of the material (see tables 5a and 5b);
- k) any heat treatment required;
- l) material certificate, if required (see 5.1).

EXAMPLE 1

Designation of a flange type 01 with facing type A and nominal size DN 800, of PN 6 with bore diameter $B_1 = 818$ mm, made of material with the symbol S235JR.

Flange EN 1092-1/01 A/DN 800/PN 6/818/S235JR

EXAMPLE 2

Designation of an ancillary component type 32 with facing type A of nominal size DN 400, PN 10 and made of material with the symbol S235JR.

Collar EN 1092-1/32 A/DN 400/PN 10/S235JR

EXAMPLE 3

Designation of a flange type 02 with facing type A of nominal size DN 400, PN 10 and made of material with the number 1.0038.

Flange EN 1092-1/02 A/DN 400/PN 10/1.0038

EXAMPLE 4

Designation of a flange type 11 with facing type B2 of nominal size DN 200, PN 100 and with neck thickness, $S = 10$ mm, made of material with the symbol 13CrMo4-5.

Flange EN 1092-1/11 B2/DN 200/PN 100/10/13CrMo4-5

5 General requirements

5.1 Flange materials

Flanges shall be manufactured from materials given in tables 5a and 5b (see also annex D). For type 11, 12 and 13 flanges, the manufacture shall be from forgings. For type 21 flanges the manufacture shall be from forgings or steel castings.

The flange manufacturer shall provide documentation to ensure traceability of material. An equipment manufacturer may require a certificate in accordance with EN 10204 which is suitable for the category of equipment to which the flange is fitted.

NOTE 1 The materials given in tables 5a and 5b (see also annex D) are tabulated in groups having the same p/T ratings as given in tables 15, 16, 17, 18, 19 and 20 (see annex B).

NOTE 2 The materials of ancillary components are not within the scope of this standard.

5.2 Repairs

Where not otherwise prohibited by the applicable material standard, repairs by welding are permitted when there is a proven method. All welding shall be carried out in accordance with a written procedure.

NOTE For approval of welding procedures, see EN 288-1. For approval of welders, see EN 287-1.

5.3 Bolting

Flanges shall be suitable for use with the number and size of bolting as specified in tables 6 to 13. The bolting shall be chosen by the equipment manufacturer according to the pressure, temperature, flange material and gasket so that the flanged joint remains tight under the expected operating conditions. For selection of bolting, see EN 1515-1, for combination of the materials of flanges and bolting see prEN 1515-2:1994, for information.

5.4 Gaskets

The various gasket types, dimensions, design characteristics and materials used are not within the scope of this standard. Dimensions of gaskets are given in EN 1514-1 to EN 1514-4.

5.5 Pressure/temperature (p/T) ratings

The p/T ratings of flanges are given in tables 15, 16, 17, 18, 19 and 20.

The p/T ratings indicate the relationship between the maximum allowable pressure PS and the maximum allowable temperature.

The p/T ratings shall apply only for flange types 05, 11, 12, 13 and 21 having nominal sizes up to and including DN 600. The p/T ratings of all other flanges shall be calculated or subject to special experience.

NOTE 1 The rules for the determination of p/T ratings of the above tables are given in annexes E and F.

NOTE 2 For the material groups 10E0 to 16E0 (austenitic steels) tables 17 and 18 should be used as follows:

- table 17 should be chosen for application in cases where the flange deformation has to be strictly limited;
- table 18 should be chosen in all cases where a small amount of plastic deformation of the flanges can be considered acceptable.

NOTE 3 Linear interpolation is permitted for intermediate temperatures.

For interpolation between (-10 °C to 50 °C) and 100 °C, 20 °C shall be used.

NOTE 4 The relevant pressures and temperatures are those of the fluid in the pipework system.

5.6 Dimensions

5.6.1 Flanges

The dimensions of flanges shall be as given in tables 6 to 13 according to the PN designation. Dimension G_{\max} may be varied from the given value (see NOTE 1) which is a maximum limit. The neck thickness, S is a minimum value, selected according to pipe thicknesses given in ISO 4200 (see NOTE 2).

NOTE 1 The centre portion of the face of a flange type 05 need not be machined provided that the diameter of the unmachined portion does not exceed the recommended diameter for G_{\max} , given in tables 6 to 13.

NOTE 2 When requested by the pressure equipment manufacturer, neck thicknesses, other than those given in the relevant tables, may be supplied by agreement with the flange manufacturer.

NOTE 3 A summary of the various types of flanges specified is given in table 3 showing the nominal sizes applicable to each type and to each PN.

NOTE 4 Diameters N_1 , N_2 and N_3 of flange types 11, 12, 13, 21 and 34 are the theoretical maximum values permitting the use of ring spanners or the application of normal series plain washers without any additional machining, e.g. spot facing (see 5.8).

NOTE 5 The bore diameters of flanges type 21 are not specified in this standard, the effective bore diameters are usually given in the relevant component standard(s).

NOTE 6 Approximate masses of flanges are given in annex C.

NOTE 7 The flange thicknesses for flanges type 05, 11, 12, 13, 21 and PN 6, PN 10, PN 16, PN 25 have an unusual step at DN 600/DN 700. This is based on a change at some flange thicknesses up to and including DN 600 to meet the pressure/temperature ratings (limited to DN 600). The flange thicknesses for flanges DN 700 and above are the same as they are given in the documents of origin (DIN, BS NFE, IBN etc.). They will be updated in future based on the flange calculation method as far as the corresponding work items of CEN/TC 74/WG 10 gives sufficient results.

NOTE 8 For flanges type 21 dimensions A , N_3 and R_1 are nominal values and are included for guidance only.

5.6.2 Hubs

The hubs of flange types 12 and 13 shall be either:

- a) parallel; or
- b) taper with an angle not exceeding 7° on the outside surface for forging or casting purposes.

Details of the weld end preparation for flanges type 11 and ancillary components type 33 shall be as given in annex A.

5.6.3 Threaded flanges

5.6.3.1 The threads of flanges type 13 shall be parallel (symbol R_p) or tapered (symbol R_c) in accordance with ISO 7-1. Gauging shall be in accordance with ISO 7-2.

NOTE Parallel threads will be supplied unless otherwise requested by the equipment manufacturer.

5.6.3.2 The thread shall be concentric with the axis of the flange and misalignments shall not exceed 5 mm per metre.

Flanges type 13 shall be manufactured without a parallel counterbore, but to protect the thread they shall be chamfered to the major diameter of the thread at the hubbed side of the flange at an angle between 30° and 50° to the axis of the thread. The chamfer shall be concentric with the thread and shall be included in the measurement of the thread length provided that the chamfer does not exceed one pitch in length.

5.6.4 Bolt holes

Bolt holes shall be equally spaced on the pitch circle diameter. In the case of flanges type 21 they shall be positioned such that they are symmetrical to the principal axes and such that no holes fall on these axes i.e. positioned "off-centre", see figures 5 to 12.

5.6.5 Lapped joints

The dimensions of lapped joints to be used with flanges, type 02 and type 04, are specified in tables 7 to 11.

For ancillary component type 33, the thickness of the lapped end at the facing shall be not less than the specified wall thickness of the pipe used.

5.7 Flange facings

5.7.1 Types of facings

The types of flange facings shall be as given in figure 3 and their dimensions shall be as given in figure 4 and table 4.

For facings types B, D, F and G, the transition from the edge of the raised face to the flange shall be:

- a) radius; or
- b) chamfer

at the choice of the flange manufacturer.

5.7.2 Jointing face finish

5.7.2.1 All flange jointing faces shall be machine finished and shall have a surface finish in accordance with the values given in table 2 when compared with reference specimens by visual or tactile means.

NOTE It is not intended that instrument measurements be taken on the faces themselves; the R_a and R_z values as defined in EN ISO 4287 relate to the reference specimens.

5.7.2.2 For flanges with facing types A, B1, E and F, turning shall be carried out with a round nosed tool in accordance with table 2.

5.7.2.3 Flanges \leq PN 40 shall have type B1 facings and flanges \geq PN 63 shall have type B2 facings, unless otherwise agreed in the order.

5.8 Spot facing or back facing of flanges

Any spot facing or back facing shall not reduce the flange thickness to less than the flange thickness specified. When spot facing is used, the diameter shall be large enough to accommodate the outside diameter of the equivalent normal series of washers in accordance with ISO 887 for the bolt size being fitted. The bearing surfaces for the bolting shall be parallel to the flange face within the limits given in table 14. When a flange is back faced a minimum fillet radius, R_2 (see figure 13) in accordance with table 21 shall be maintained.

5.9 Tolerances

Tolerances on dimensions of flanges shall be as given in table 14.

5.10 Marking

5.10.1 General marking requirements

All flanges, other than type 21 flanges, shall be marked as follows:

- a) Flange manufacturer's name or trade mark, e.g. XXX;
- b) Number of this standard, i.e. EN 1092-1;
- c) Flange type number, e.g. 11;
- d) DN, e.g. DN 150;
- e) PN designation, e.g. PN 40;
- f) Neck thickness (S), if not to this standard;
- g) For EN materials – either the symbol or the number or the grade of the material, e.g. S235JR;
For ASTM materials - the material grade, preceded by the specification number where necessary, e.g. WC 4;
- h) Cast number of melt identification or suitable control number traceable to the cast number, e.g. 12345, when test certification is required.

EXAMPLE XXX/EN 1092-1/11/DN 150/PN 40/S235JR/12345

If a flange is too small to enable all the markings required then the minimum marking required shall be:

- a) Flange manufacturer's name or trade mark;
- b) letters "EN";
- e) PN designation e.g. PN 40;
- g) either the symbol or the number or the grade of the material;
- h) cast number or melt identification or suitable control number.

5.10.2 Stamping

Where steel stamps are used, the marking shall be positioned on the outer rim of the flange.

NOTE It should be ensured that steel stamp markings are not liable to cause cracks in the flange material.

5.10.3 Declaration of compliance

The marking EN 1092-1, together with the flange manufacturer's name or trademark on or in relation to a product, represents the flange manufacturer's declaration of compliance to this standard, i.e. a claim by or on behalf of the flange manufacturer that the product meets the requirements of this standard.

ZIZI ENGINEERING CO LTD

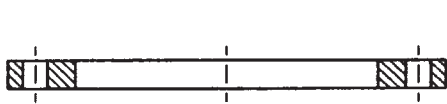

Type 01
Plate flange for welding

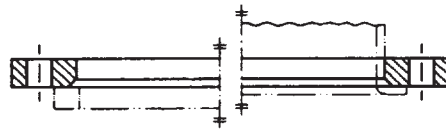

Type 02
Loose plate flange with weld-on collar (see type 32) or lapped pipe end (see type 33)

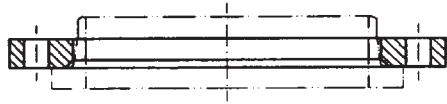

Type 04
Loose plate flange with weld-neck collar (see type 34)

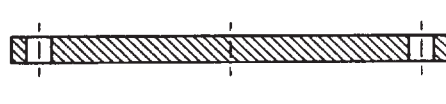

Type 05
Blank flange

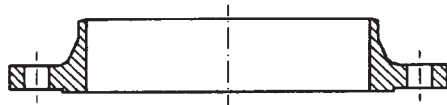

Type 11
Weld-neck flange



Type 12
Hubbed slip-on flange for welding

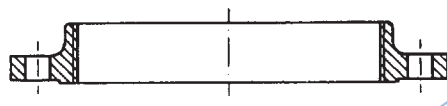

Type 13
Hubbed threaded flange

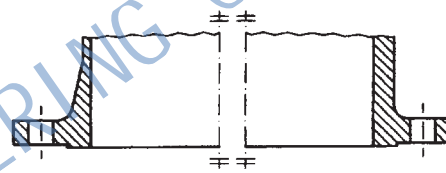

Type 21
Integral flange

NOTE These sketches are diagrammatic only, in particular no detail is shown for the mating surfaces (see figure 3).

Figure 1 - Flange types

Table 1 - Types of steel flanges and ancillary components

Type No	Description
01	Plate flange for welding
02	Loose plate flange with weld-on plate collar or for lapped pipe end
04	Loose plate flange with weld-neck collar
05	Blank flange
11	Weld-neck flange
12	Hubbed slip-on flange for welding
13	Hubbed threaded flange
21 ^a	Integral flange
32 ^b	Weld-on plate collar
33 ^b	Lapped pipe end
34 ^b	Weld-neck collar

^a Flange type 21 is an integral part of some other equipment or component.

^b Ancillary components type numbers 32 and 33 are for use with type 02 flanges and type number 34 for use with type 04 flanges.

NOTE Type numbers have been made non-consecutive to permit possible future additions.

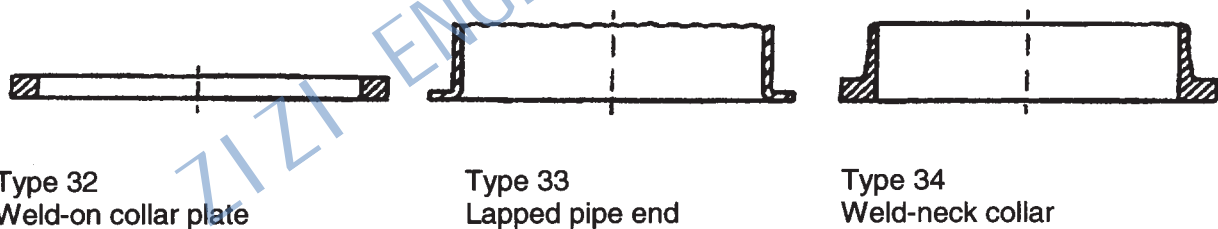

NOTE These sketches are diagrammatic only.

Figure 2 - Ancillary components Types 32 to 34

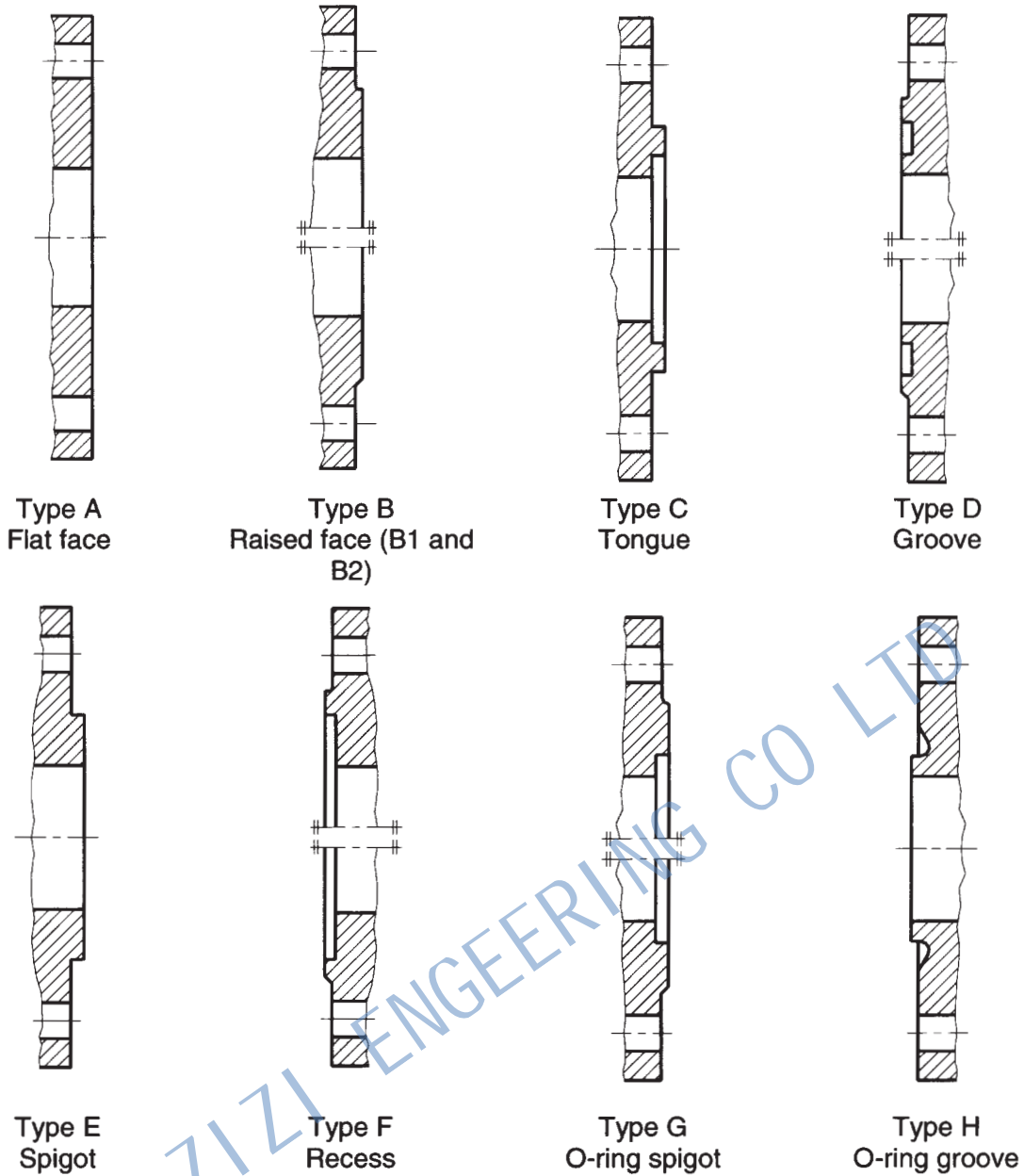

NOTE 1 The transition from the edge of the raised face to the flange face may be by radius or chamfer for types B, D, F and G only (see 5.7.1).

NOTE 2 B1 and B2 are raised face (type B) for different applications (see 5.7.2.2, 5.7.2.3 and table 2).

NOTE 3 For the dimensions of flange facings, see figure 4 and table 4.

Figure 3 - Flange facing types

Table 2 - Surface finish for jointing faces

Facing types	Method of machining	Radius of tool nose mm min.	R_a^a		R_z^a	
			μm		μm	
			min.	max.	min.	max.
A, B1 ^b , E, F	Turning ^c	1,0	3,2	12,5	12,5	50
B2 ^b , C, D, G, H	Turning ^c	-	0,8	3,2	3,2	12,5

^a R_a and R_z are defined in EN ISO 4287.

^b Types B1 and B2 are raised face (type B) flanges with different specified surface roughness values for the following applications:

B1 for PN 2,5 up to PN 40;

B2 for PN 63 and PN 100.

^c The term 'turning' includes any method of machine operation producing either serrated concentric or serrated spiral grooves.

NOTE For certain applications, e.g. low temperature gases, it may be necessary to stipulate closer control to the surface finish.

ZIZI ENGINEERING CO. LTD

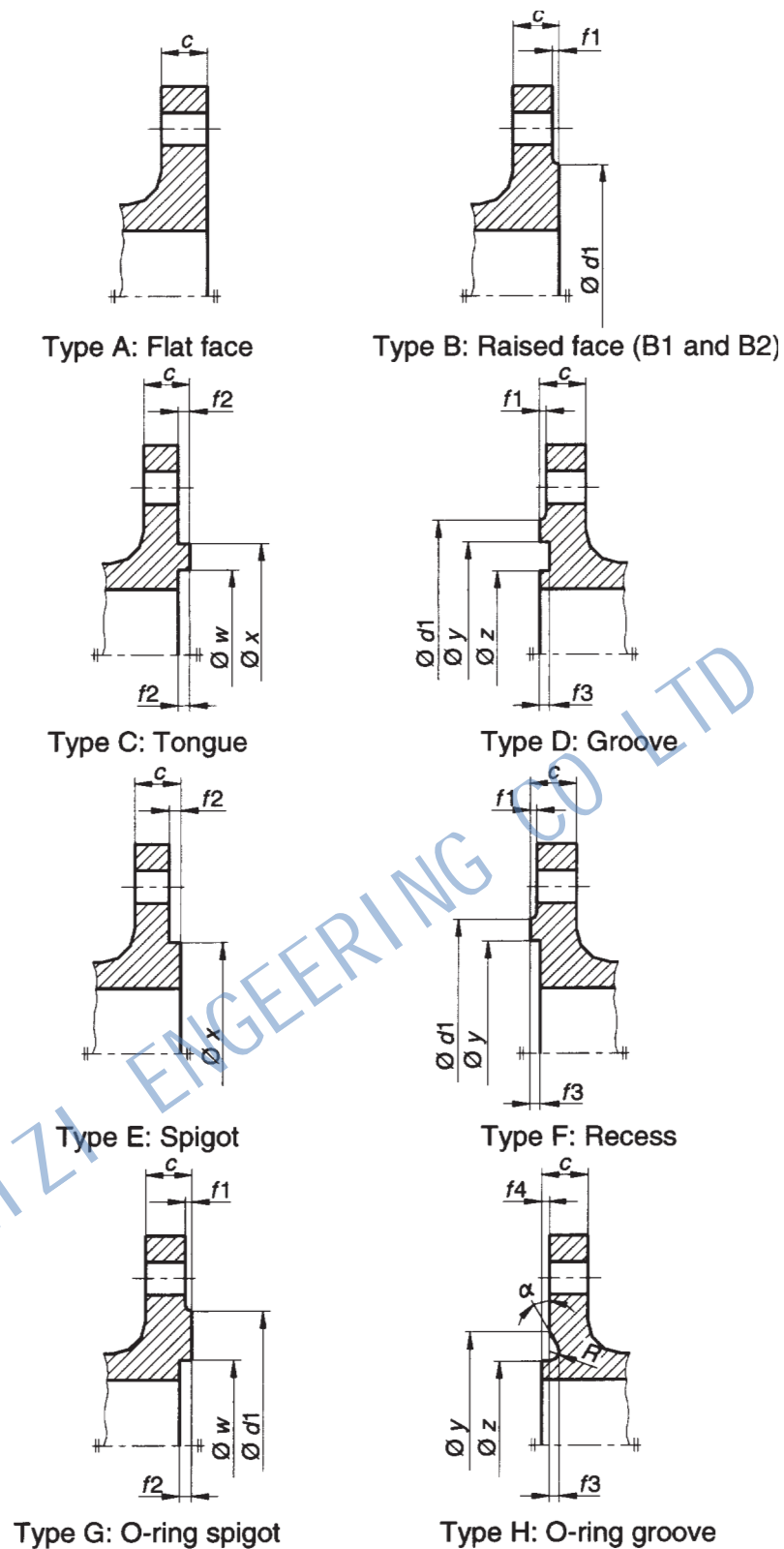

NOTE 1 Dimension C includes the raised face thickness.
NOTE 2 Cross section diameter of the O-ring is $2 \times R$.

Figure 4 - Flange facing (dimensions see table 4)

Table 5a - Materials-EN

Group	Forgings			Castings			Hot rolled products		
	Symbol	Standard	Material number	Symbol	Standard	Material number	Symbol	Standard	Material number
1E0	S235JR	EN 10025	1.0037	-	-	-	S235JR	EN 10025	1.0037
1E1	S235JRG2	EN 10025	1.0038	-	-	-	S235JRG2	EN 10025	1.0038
2E0	-	-	-	-	-	-	-	-	-
3E0	P245GH	EN 10222-2	1.0352	GP240GR	EN 10213-2	1.0621	P245GH	EN 10028-2	1.0425
3E1	P280GH	EN 10222-2	1.0426	GP240GH	EN 10213-2	1.0619	P280GH	EN 10028-2	1.0481
4E0	17Mo3	EN 10222-2	1.5445	G20Mo5	EN 10213-2	1.5419	16Mo3	EN 10028-2	1.5415
5E0	14CrMo4-5	EN 10222-2	1.7335	G17CrMo5-5	EN 10213-2	1.7357	13CrMo4-5	EN 10028-2	1.7335
6E0	11CrMo9-10	EN 10222-2	1.7383	G17CrMo9-10	EN 10213-2	1.7379	11CrMo9-10	EN 10028-2	1.7383
6E1	X16CrMo5-1+NT	EN 10222-2	1.7366	GX15CrMo5	EN 10213-2	1.7365	-	-	-
7E0	13MnNi6-3	EN 10222-3	1.6217	G17Mn5	EN 10213-3	1.1131	P275NL1	EN 10028-3	1.0488
	-	-	-	G20Mn5	EN 10213-3	1.6220	P275NL2	EN 10028-3	1.1104
7E1	-	-	-	-	-	-	11MnNi5-3	EN 10028-4	1.6212
	-	-	-	-	-	-	P355NL1	EN 10028-3	1.0566
	-	-	-	-	-	-	P355NL2	EN 10028-3	1.1106
	-	-	-	-	-	-	15NiMn6	EN 10028-4	1.6228
7E2	15NiMn6	EN 10222-3	1.6228	G9Ni14	EN 10213-3	1.5638	12Ni14	EN 10028-4	1.5637
	-	-	-	-	-	-	12Ni19	EN 10028-4	1.5680
7E3	12Ni19	EN 10222-3	1.5637	-	-	-	X8Ni9	EN 10028-4	1.5662
	-	-	-	-	-	-	11MnNi5-3	EN 10028-4	1.6212
	-	-	-	-	-	-	12Ni14	EN 10028-4	1.5637
	-	-	-	-	-	-	12Ni19	EN 10028-4	1.5680
	-	-	-	-	-	-	X8Ni9	EN 10028-4	1.5662
8E0	-	-	-	-	-	-	P275N	EN 10028-3	1.0486
8E1	-	-	-	-	-	-	P355N	EN 10028-3	1.0562
8E2	P285NH	EN 10224-4	1.0487	-	-	-	P275NH	EN 10028-3	1.0487
8E3	P355NH	EN 10222-4	1.0565	-	-	-	P355NH	EN 10028-3	1.0565
9E0	X20CrMoV11-1	EN 10222-2	1.4922	GX23CrMoV12-1	EN 10213-2	1.4931	-	-	-
10E0	X2CrNi18-9	EN 10222-5	1.4307	GX2CrNi19-11	EN 10213-4	1.4309	X2CrNi18-9	EN 10028-7	1.4306
10E1	X2CrNi18-10	EN 10222-5	1.4311	-	-	-	X2CrNi18-10	EN 10028-7	1.4311
11E0	X5CrNi18-10	EN 10222-5	1.4301	GX5CrNi19-10	EN 10213-4	1.4308	X5CrNi18-10	EN 10028-7	1.4301
12E0	X6CrNiTi18-10	EN 10222-5	1.4541	-	-	-	X6CrNiTi18-10	EN 10028-7	1.4541
	-	-	-	GX5CrNiNb19-11	EN 10213-4	1.4552	X6CrNiNb18-10	EN 10028-7	1.4550
13E0	X2CrNiMo17-12-2	EN 10222-5	1.4404	GX2CrNiMo19-11-2	EN 10213-4	1.4409	X2CrNiMo17-12-2	EN 10028-7	1.4404
13E1	X2CrNiMoN17-11-2	EN 10222-5	1.4406	-	-	-	-	-	-
14E0	X5CrNiMo17-12-2	EN 10222-5	1.4401	GX5CrNiMo19-11-2	EN 10213-4	1.4408	X5CrNiMo17-12-2	EN 10028-7	1.4401
15E0	X6CrNiMoTi17-12-2	EN 10222-5	1.4571	-	-	-	X6CrNiMoTi17-12-2	EN 10028-7	1.4571
	-	-	-	GX5CrNiMoNb19-11-2	EN 10213-4	1.4581	X6CrNiMoNb17-12-2	EN 10028-7	1.4580
16E0	-	-	-	GX2CrNiMoCuN25-6-3-3	EN 10213-4	1.4517	-	-	-
	-	-	-	GX2CrNiMoN26-7-4	EN 10213-4	1.4469	-	-	-

Table 5b - Materials - ASTM

Material group	Specification and grade									
	Casting		Forging			Plate				
	Standard	Grade	Standard	Grade	Standard	Grade				
1C1	ASTM A216 ^{a,b} ASTM A352	WCB	ASTM A105 ^{a,b} ASTM A350	LF2 ^c	ASTM 515 ASTM A516 ASTM A537	70 ^{a,b} 70 ^{a,d} CL1 ^c				
1C2	ASTM A216 ASTM A352	WCC ^{a,b)} LC2 ^c , LC3 ^c , LOC ^c	ASTM A350	LF3 ^c	ASTM A203	B ^{a,b} , E ^{a,b}				
1C3	ASTM A352 ^a	LCB	-	-	ASTM A203 ASTM A515 ASTM A516	A ^{a,b} , D ^{a,b} 65 ^{a,b} 65 ^{a,d}				
1C4	-	-	ASTM A350 ^c	LF1	ASTM A515 ASTM A516	60 ^{a,b} 60 ^{a,d}				
1C5	ASTM A217 ^{b,a} ASTM A325 ^c	WC1 LC1	ASTM A182 ^{b,e}	F1	ASTM A204	A ^{b,e} , B ^{b,e}				
1C7	ASTM A217	WC4 ^b , WC5 ^f	ASTM A182 ^b	F2	ASTM A204 ^d	C				
1C9	ASTM A217 ^g	WC6	ASTM A182	F11 ^h , F12 ^h	ASTM A387 ^h	11CL2				
1C10	ASTM A217 ^g	WC9	ASTM A182 ^g	F22	ASTM A387 ^h	22CL2				
1C13	ASTM A217	C5	ASTM A182	F5, F5A	-	-				
1C14	ASTM A217	C12	ASTM A182	F9	-	-				
2C1	ASTM A351	CF8, CF3 ⁱ	ASTM A182	F304, F304H	ASTM A240	304, 304H ⁱ				
2C2	ASTM A351	CF8M, CF3M ^a	ASTM A182	F316, F316H	ASTM A240	316, 317, 316H ^d				
2C3	-	-	ASTM A182	F304L ⁱ , F316L ^d	ASTM A240	304L ⁱ , 316L ^d				
2C4	-	-	ASTM A182	F321 ^b , F321H	ASTM A240	321 ^b , 321H				
2C5	-	-	ASTM A182	F347 ^b , F347H, F348 ^b , F348H	ASTM A240	347 ^b , 347H, 348 ^b , 348H				
2C6	ASTM A351	CH8, CH20	-	-	ASTM A240	309S				
2C7	ASTM A351	CK20	ASTM A182 ^j	F310	ASTM A240 ⁱ	310S				

^a Permissible but not recommended for use above 425 °C.

^b Not to be used over 540 °C.

^c Not to be used over 345 °C.

^d Not to be used over 455 °C.

^e Permissible but not recommended for prolonged use above about 455 °C.

^f Not to be used over 565 °C.

^g Not to be used over 590 °C.

^h Permissible but not recommended for prolonged use above about 590 °C.

ⁱ Not to be used over 425 °C.

^j For service temperature 565 °C and above, should be used only when assurance is provided that grain size is not greater than ASTM No 6.

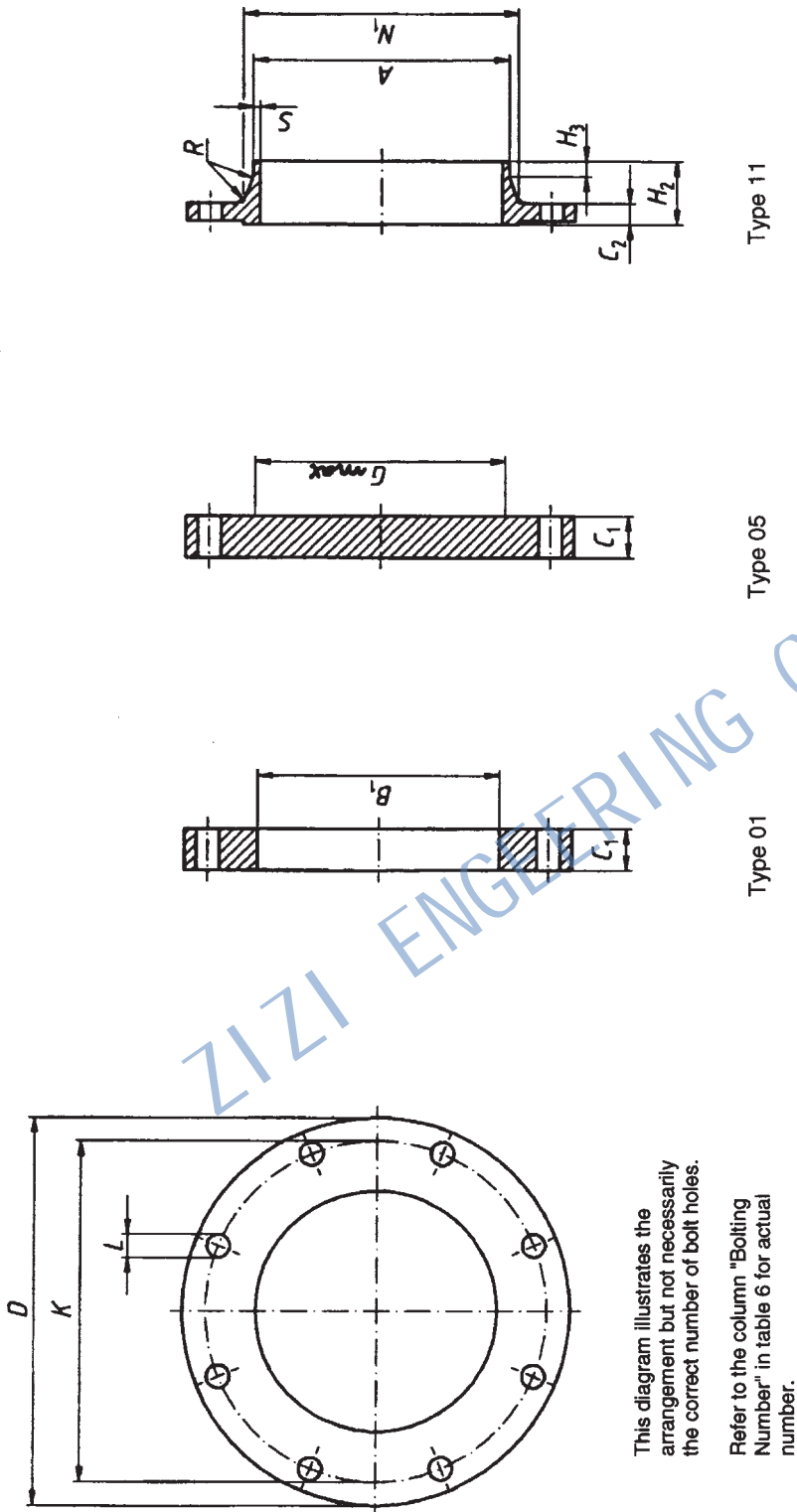

NOTE 1 Dimension M_1 is measured at the intersection of the hub draft angle and the back face of the flange.

NOTE 2 For dimension G_{max} refer to NOTE 1 of 5.6.1.

Figure 5 - Dimensions of PN 2,5 flanges

Table 6 - Dimensions of PN 2,5 flanges

DN	Mating dimensions						Outside diameter of neck A	Bore diameter B ₁	Flange type			Lengths			Neck diameter N ₁	Corner radii R ₁	Neck thickness (see 5.6.1) S	
	Outside diameter D	Diameter of bolt circle K	Diameter of bolt hole L	Bolting		C ₁			C ₂	G _{max}	H ₂	H ₃	N ₁	R ₁				S
				Number	Size													
	Flange type																	
01, 05, 11																		
10 to 1000	Use PN 6 rating (dimensions for these sizes are identical)																	
1200	1375	1320	30	32	M27	1219		26	1160	70	16	1245	16	7				
1400	1575	1520	30	36	M27	1422		26	1346	70	16	1445	16	7				
1600	1790	1730	30	40	M27	1626		26	1546	80	20	1645	16	8				
1800	1990	1930	30	44	M27	1829		26	1746	80	20	1845	16	9				
2000	2190	2130	30	48	M27	2032		26	1950	80	22	2045	16	10				
2200	2405	2340	33	52	M30	2235		28	-	90	25	2248	18	10				
2400	2605	2540	33	56	M30	2438	To be specified by the purchaser	28	-	90	25	2448	18	10				
2600	2805	2740	33	60	M30	2620	To be specified by the purchaser	28	-	90	25	2648	18	10				
2800	3030	2960	36	64	M33	2820	To be specified by the purchaser	30	-	90	25	2848	18	10				
3000	3230	3160	36	68	M33	3020	To be specified by the purchaser	30	-	90	25	3050	18	10				
3200	3430	3360	36	72	M33	3220	To be specified by the purchaser	30	-	90	25	3250	20	10				
3400	3630	3560	36	76	M33	3420	To be specified by the purchaser	32	-	95	28	3450	20	10				
3600	3840	3770	36	80	M33	3620	To be specified by the purchaser	32	-	100	28	3652	20	10				
3800	4045	3970	39	80	M36	3820	To be specified by the purchaser	34	-	100	28	3852	20	10				
4000	4245	4170	39	84	M36	4020	To be specified by the purchaser	34	-	100	28	4052	20	10				

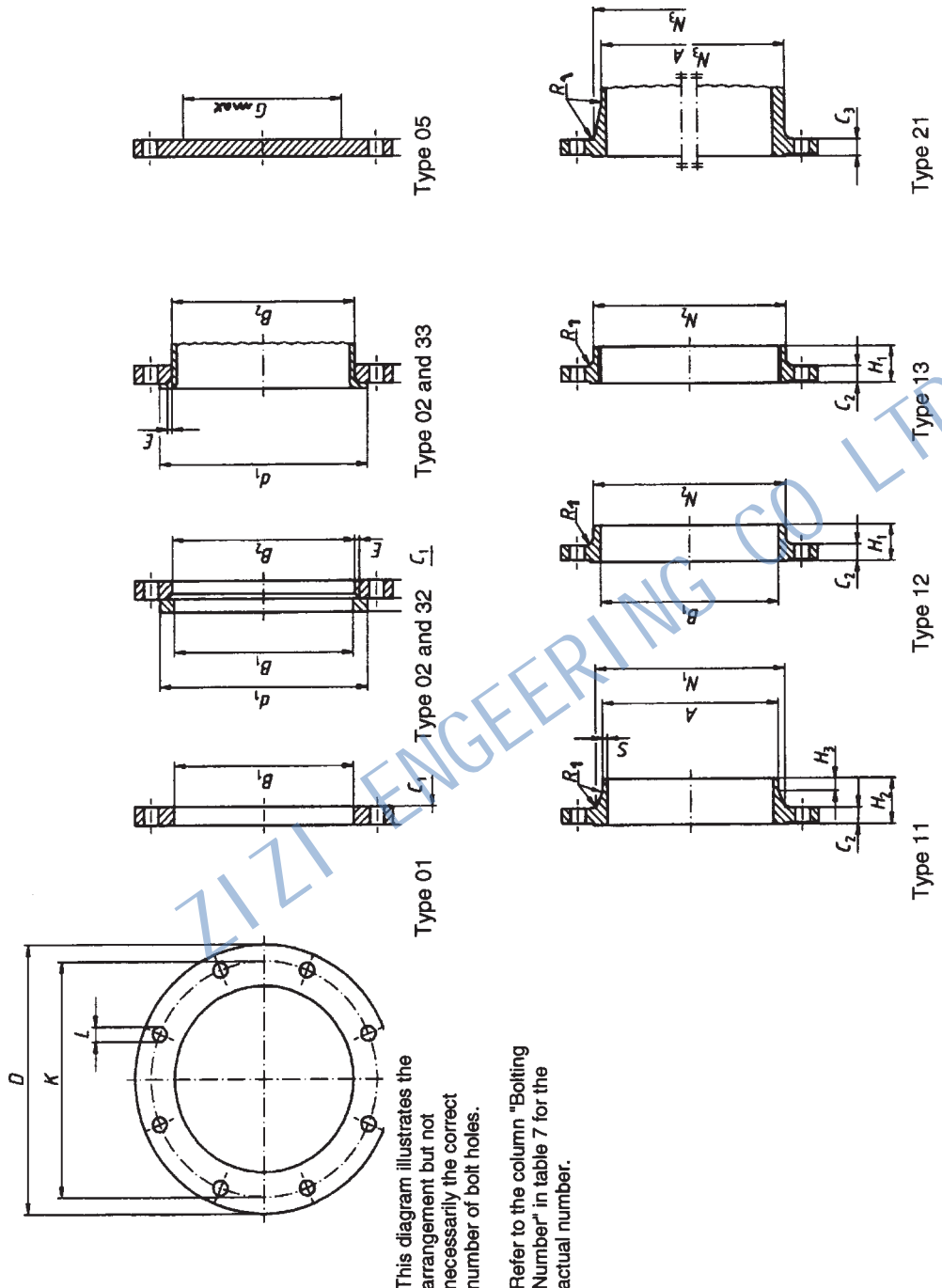

This diagram illustrates the arrangement but not necessarily the correct number of bolt holes.

Refer to the column "Bolting Number" in table 7 for the actual number.

NOTE 1 Dimensions N_1 , N_2 and N_3 are measured at the intersection of the hub draft angle and the back face of the flange.

NOTE 2 For dimension d_1 , see table 4.

NOTE 3 For dimensions G_{max} refer to NOTE 1: of 5.6.1.

NOTE 4 Type 33; lapped pipe end without determination of thickness.

Figure 6 - Dimensions of PN 6 flanges

Table 7 - Dimensions of PN 6 flanges

Dimensions in millimetres																											
DN	Mating dimensions				Outside diameter of neck	Bore diameters		Flange thickness			Chamfer	Collar thickness	Diameter of shoulder	Length			Neck diameters			Corner radii	Neck thickness (see 5.6.1)						
	D	Diameter of bolt circle	Diameter of bolt hole	Bolting		A	B ₁	B ₂	C ₁ ^a	C ₂				C ₃	E	F	G _{max}	H ₁	H ₂			H ₃	N ₁	N ₂	N ₃	R ₁	S
Flange type																											
01, 02, 05, 11, 12, 13, 21																											
10	75	50	11	4	M10	17,2	18,0	21	12	12	12	3	10	-	20	28	6	26	25	20	4	1,8					
15	80	55	11	4	M10	21,3	22,0	25	12	12	12	3	10	-	20	30	6	30	30	26	4	2,0					
20	90	65	11	4	M10	26,9	27,5	31	14	14	14	4	10	-	24	32	6	38	40	34	4	2,3					
25	100	75	11	4	M10	33,7	34,5	38	14	14	14	4	10	-	24	35	6	42	50	44	4	2,6					
32	120	90	14	4	M12	42,4	43,5	46	16	14	14	5	10	-	26	35	6	55	60	54	6	2,6					
40	130	100	14	4	M12	48,3	49,5	53	16	14	14	5	10	-	26	38	7	62	70	64	6	2,6					
50	140	110	14	4	M12	60,3	61,5	65	16	14	14	5	12	-	28	38	8	74	80	74	6	2,9					
65	160	130	14	4	M12	76,1	77,5	81	16	14	14	6	12	55	32	38	9	88	100	94	6	2,9					
80	190	150	18	4	M16	88,9	90,5	94	18	16	16	6	12	70	34	42	10	102	110	110	8	3,2					
100	210	170	18	4	M16	114,3	116,0	120	18	16	16	6	14	90	40	45	10	130	130	130	8	3,6					
125	240	200	18	8	M16	139,7	141,5	145	20	18	18	6	14	115	44	48	10	155	180	160	8	4,0					
150	265	225	18	8	M16	168,3	170,5	174	20	18	18	6	14	140	44	48	12	184	185	182	10	4,5					
200	320	280	18	8	M16	219,1	221,5	226	22	20	20	6	16	190	44	55	15	236	240	238	10	6,3					
250	375	335	18	12	M16	273,0	276,5	281	24	22	22	8	18	235	44	60	15	290	295	284	12	6,3					
300	440	395	22	12	M20	323,9	327,5	333	24	22	22	8	18	285	44	62	15	342	355	342	12	7,1					
350	490	445	22	12	M20	355,6	359,5	365	26	22	22	8	18	330	-	62	15	385	-	392	12	7,1					
400	540	495	22	16	M20	406,4	411,0	416	28	22	22	8	20	380	-	65	15	438	-	442	12	7,1					
450	595	550	22	16	M20	457,0	462,0	467	30	22	24	8	20	425	-	65	15	492	-	494	12	7,1					

(continued)

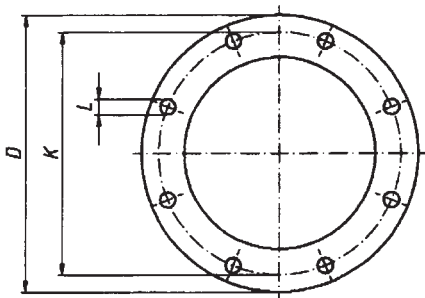

This diagram illustrates the arrangement but not necessarily the correct number of bolt holes.

Refer to the column "Bolting Number" in table 8 for the actual number.

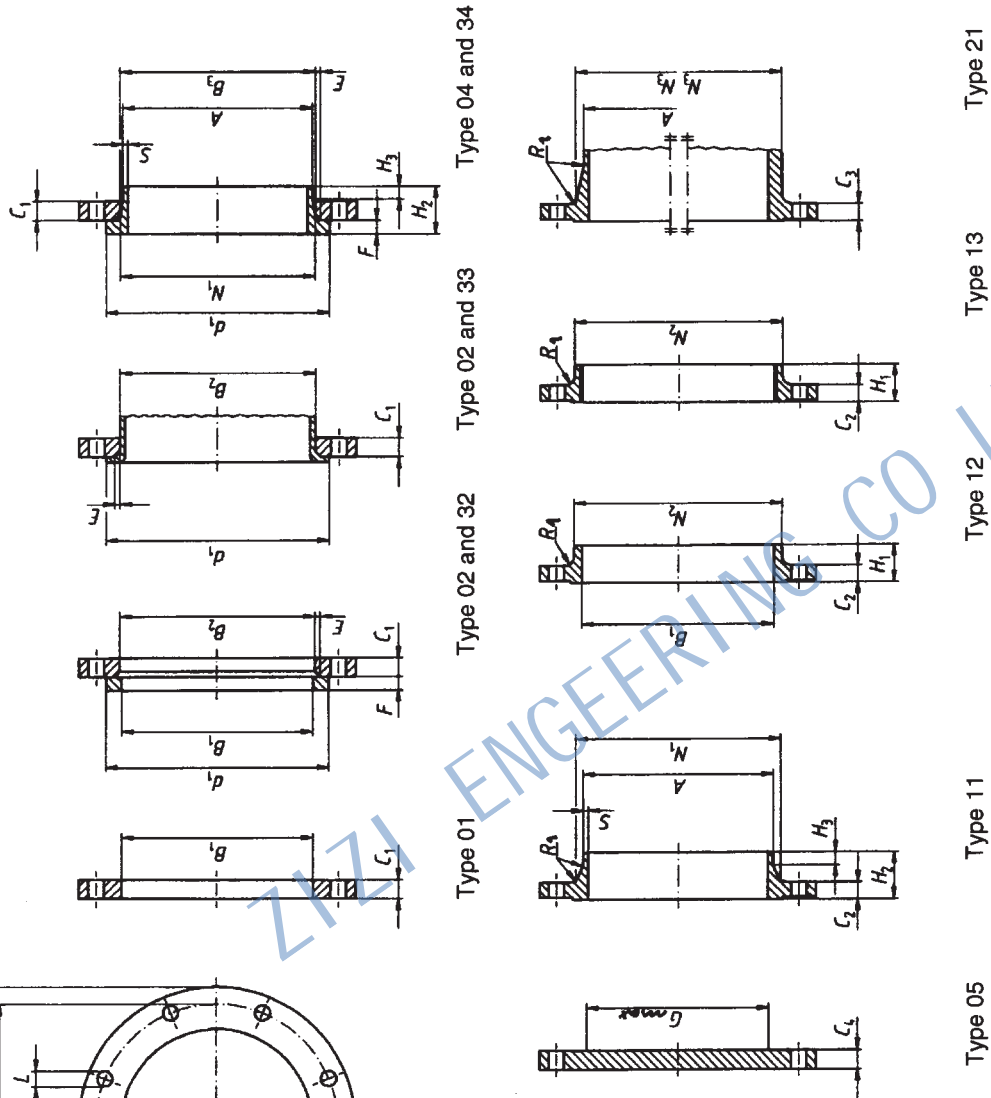

NOTE 1 Dimensions M_1 , M_2 , and M_3 are measured at the intersection of the hub draft angle and the back face of the flange.

NOTE 2 For dimensions d_1 see table 4.

NOTE 3 For dimensions G_{max} refer to NOTE 1 of 5.6.1.

NOTE 4 Type 33; lapped pipe end without determination of thickness.

Figure 7 - Dimensions of PN 10 flanges

Table 8 - Dimensions of PN 10 flanges

DN	Mating dimensions						Dimensions in millimetres																											
	Outside diameter	Diameter of bolt circle	Diameter of bolt hole	Bolting		Outside diameter of neck	Bore diameters					Flange thickness			Chamfer	Collar thickness	Diameter of shoulder	Length			Neck diameters			Corner radii	Neck thickness (see 5.5.1)									
				K	L		Number	Size	A	B ₁	B ₂	B ₃	C ₁	C ₂				C ₃	C ₄	E	F	G _{max}	H ₁			H ₂	H ₃	N ₁	N ₂	N ₃	R ₁	S		
	Flange type																																	
	01, 02, 04, 05, 11, 12, 13, 21																																	
10 to 40	11	21*	34		01	02	04	01	11	12	13	05	02	04	05	05	12	13	11	11	12	13	21	11	11	12	12	12	13	13	21	11	11	34
50 to 150	Use PN 40 dimensions																																	
	Use PN 16 dimensions																																	
200	340	295	22	8	M20	219,1	221,5	226	240	24	24	24	24	24	24	24	24	24	24	24	24	24	6	20	190	44	62	16	234	246	246	246	10	6,3
250	395	350	22	12	M20	273,0	276,5	281	294	26	26	26	26	26	26	26	26	26	26	26	26	8	22	235	46	68	16	292	298	298	298	12	6,3	
300	445	400	22	12	M20	323,9	327,5	333	348	26	26	26	26	26	26	26	26	26	26	26	26	8	22	285	46	68	16	342	350	348	350	12	7,1	
350	505	460	22	16	M20	335,6	359,5	365	400	28	26	26	26	26	26	26	26	26	26	26	26	8	22	330	53	68	16	385	400	408	408	12	7,1	
400	565	515	26	16	M24	406,4	411,0	416	450	32	26	26	26	26	26	26	26	26	26	26	26	8	24	380	57	72	16	440	456	456	456	12	7,1	
450	615	565	26	20	M24	457,0	462,0	467	498	36	28	28	28	28	28	28	28	28	28	28	28	8	24	425	63	72	16	488	502	502	502	12	7,1	
500	670	620	26	20	M24	508,0	513,5	519	550	38	28	28	28	28	28	28	28	28	28	28	28	8	26	475	67	75	16	542	559	559	559	12	7,1	
600	780	725	30	20	M27	610,0	616,5	622	650	42	28	34	34	34	34	34	34	34	34	34	34	8	26	575	75	80	18	642	658	658	658	12	7,1	
700	895	840	30	24	M27	711,0	-	-	-	-	30	34	38	-	-	-	-	-	-	-	-	-	-	-	670	-	80	18	746	-	-	-	12	8,0
800	1015	950	33	24	M30	813,0	-	-	-	-	32	36	42	-	-	-	-	-	-	-	-	-	-	-	770	-	90	18	850	-	-	-	12	8,0
900	1115	1050	33	28	M30	914,0	-	-	-	-	34	38	46	-	-	-	-	-	-	-	-	-	-	-	860	-	95	20	950	-	-	-	12	10,0
1000	1230	1160	36	28	M33	1016,0	-	-	-	-	34	38	52	-	-	-	-	-	-	-	-	-	-	-	960	-	95	20	1052	-	-	-	16	10,0
1200	1455	1380	39	32	M36	1219,0	-	-	-	-	38	44	60	-	-	-	-	-	-	-	-	-	-	-	1160	-	115	25	1256	-	-	-	16	11,0
1400	1675	1590	42	36	M39	1422,0	-	-	-	-	42	48	-	-	-	-	-	-	-	-	-	-	-	-	-	-	120	25	1460	-	-	-	16	12,0
1600	1915	1820	48	40	M45	1626,0	-	-	-	-	46	52	-	-	-	-	-	-	-	-	-	-	-	-	-	-	130	25	1666	-	-	-	16	14,0
1800	2115	2020	48	44	M45	1829,0	-	-	-	-	50	56	-	-	-	-	-	-	-	-	-	-	-	-	-	-	140	30	1868	-	-	-	16	15,0
2000	2325	2230	48	48	M45	2032,0	-	-	-	-	54	60	-	-	-	-	-	-	-	-	-	-	-	-	-	-	150	30	2072	-	-	-	16	16,0
2200	2550	2440	56	52	M52	2235,0	-	-	-	-	58	-	-	-	-	-	-	-	-	-	-	-	-	-	-	-	160	35	2275	-	-	-	18	18,0
2400	2760	2650	56	56	M52	2438,0	-	-	-	-	62	-	-	-	-	-	-	-	-	-	-	-	-	-	-	-	170	35	2478	-	-	-	18	20,0
2600	2960	2850	56	60	M52	2620,0	-	-	-	-	66	-	-	-	-	-	-	-	-	-	-	-	-	-	-	-	180	40	2680	-	-	-	18	22,0
2800	3180	3070	56	64	M52	2820,0	-	-	-	-	70	-	-	-	-	-	-	-	-	-	-	-	-	-	-	-	190	40	2882	-	-	-	18	22,0
3000	3405	3290	62	68	M56	3020,0	-	-	-	-	75	-	-	-	-	-	-	-	-	-	-	-	-	-	-	-	200	45	3085	-	-	-	18	24,0

* For flanges type 21 the outside hub diameter approximately corresponds to the outside pipe diameter.

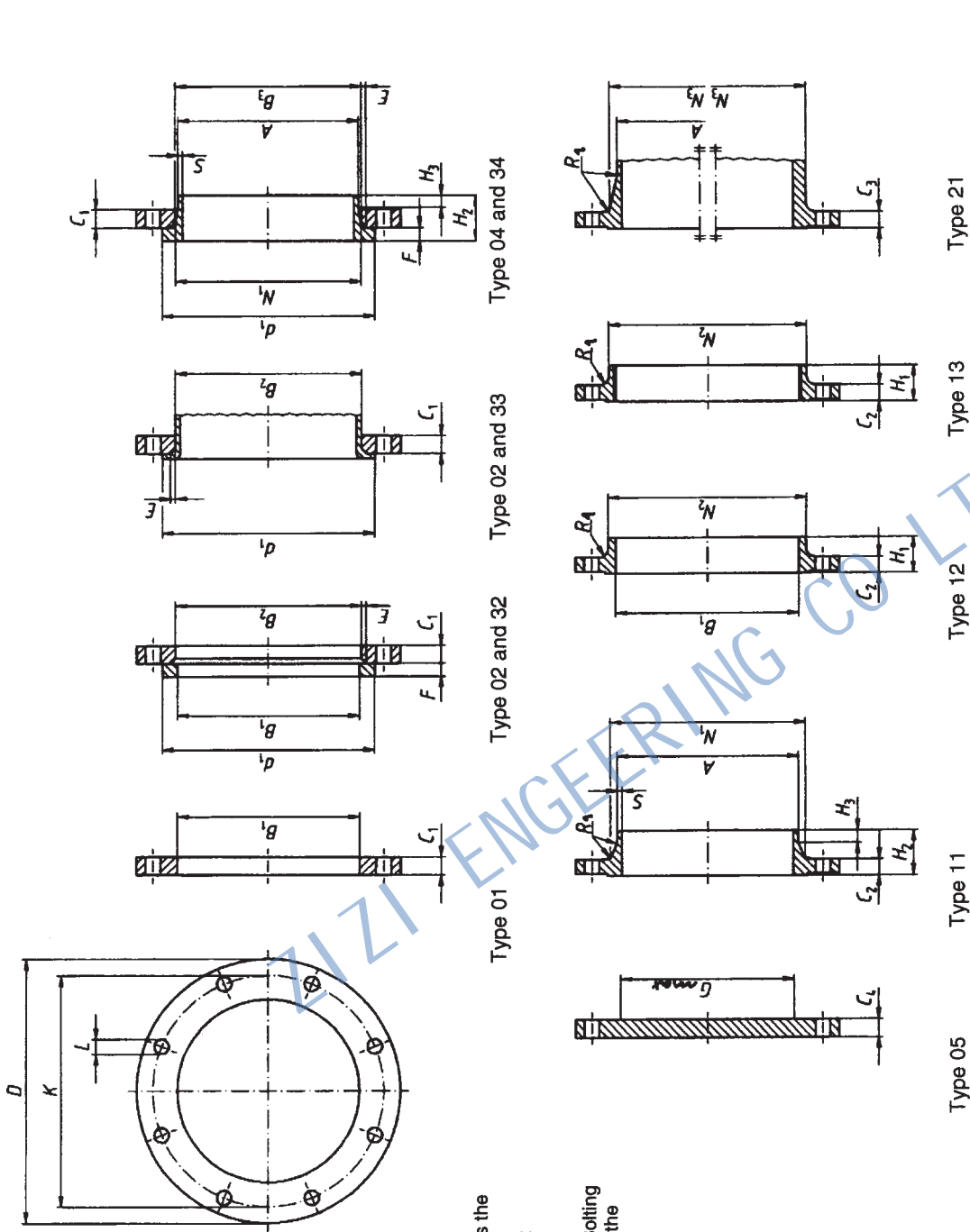

This diagram illustrates the arrangement but not necessarily the correct number of bolt holes.

Refer to the column "Bolting Number" in table 9 for the actual number.

NOTE 1 Dimensions N_1 , N_2 , and N_3 are measured at the intersection of the hub draft angle and the back face of the flange.

NOTE 2 For dimensions d_1 see table 4.

NOTE 3 For dimensions G_{max} refer to NOTE 1 of 5.6.1.

NOTE 4 Type 33; lapped pipe end without determination of thickness.

Figure 8 - Dimensions of PN 16 flanges

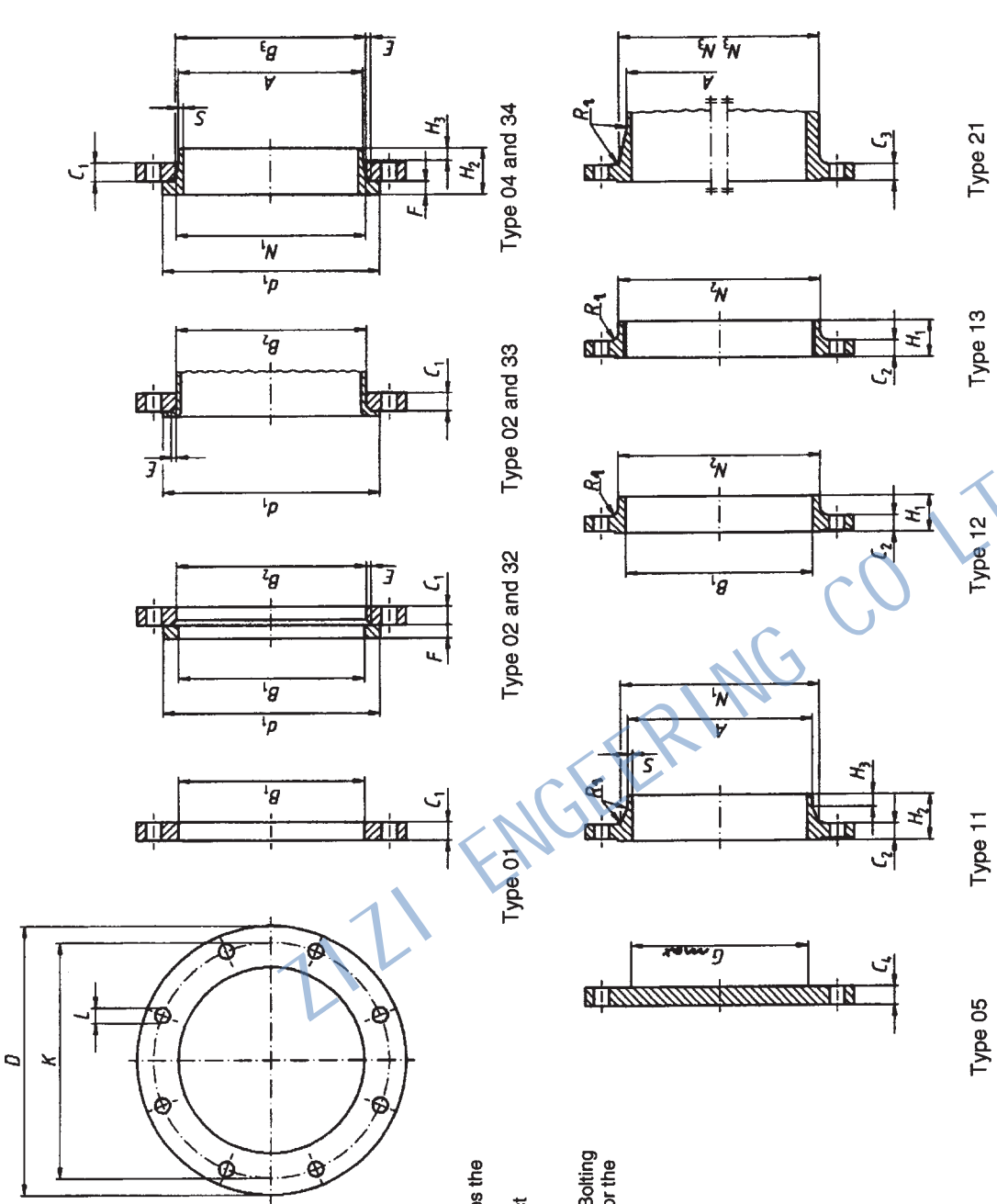

This diagram illustrates the arrangement but not necessarily the correct number of bolt holes.

Refer to the column "Bolting Number" in table 10 for the actual number.

- NOTE 1 Dimensions M_1 , M_2 , and M_3 are measured at the intersection of the hub draft angle and the back face of the flange.
- NOTE 2 For dimensions d_1 see table 4.
- NOTE 3 For dimensions G_{max} refer to NOTE 1 of 5.6.1.
- NOTE 4 Type 33; lapped pipe end without determination of thickness.

Figure 9 - Dimensions of PN 25 flanges

Table 10 - Dimensions of PN 25 flanges

DN	Mating dimensions				Bore diameters			Flange thickness				Chamfer	Collar thickness	Diameter of shoulders	Length			Neck diameters			Corner radii	Neck thickness (see 5.6.1)			
	Outside diameter D	Diameter of bolt circle K	Diameter of bolt hole L	Bolting	Number	Size	A	B ₁	B ₂	B ₃	C ₁				C ₂	C ₃	C ₄	E	F	G max			H ₁	H ₂	H ₃
												01	02	04							05	02			
10 to 150	Flange type																								
	Use PN 40 dimensions																								
200	360	310	26	12	M24	219,1	221,5	226	250	32	30	30	30	6	26	190	52	80	16	244	256	252	10	6,3	
250	425	370	30	12	M27	273,0	276,5	281	302	35	32	32	32	8	26	235	60	88	18	298	310	304	12	7,1	
300	485	430	30	16	M30	323,9	327,5	333	356	38	34	34	34	8	28	285	67	92	18	362	364	364	12	8,0	
350	555	490	33	16	M33	355,6	359,5	365	408	42	38	38	38	8	32	332	72	100	20	398	418	418	12	8,0	
400	620	550	36	16	M33	406,4	411,0	416	462	46	40	40	40	8	34	380	78	110	20	452	472	472	12	8,8	
450	670	600	36	20	M33	457,0	462,0	467	510	50	46	46	46	8	36	425	84	110	20	500	520	520	12	8,8	
500	730	660	36	20	M36	508,0	513,5	519	568	56	48	48	48	8	38	475	90	125	20	558	580	580	12	10,0	
600	845	770	39	20	M36	610,0	616,5	622	670	68	58	58	58	8	40	575	100	125	20	660	684	684	12	11,0	
700	960	875	42	24	M39	711,0	-	-	-	-	46	50	-	-	-	-	-	125	20	780	780	780	12	12,5	
800	1085	990	48	24	M45	813,0	-	-	-	-	50	54	-	-	-	-	-	135	22	864	882	882	12	14,2	
900	1185	1090	48	28	M45	914,0	-	-	-	-	54	58	-	-	-	-	-	145	24	968	982	982	12	16,0	
1000	1320	1210	56	28	M52	1016,0	-	-	-	-	58	62	-	-	-	-	-	155	24	1070	1086	1086	16	17,5	
1200	1530	1420	56	32	M52	1219,0	-	-	-	-	70	70	-	-	-	-	-	-	-	-	1296	18	-	-	
1400	1755	1640	62	36	M56	1422,0	-	-	-	-	76	76	-	-	-	-	-	-	-	-	1508	18	-	-	
1600	1975	1860	62	40	M56	1626,0	-	-	-	-	84	84	-	-	-	-	-	-	-	-	1726	20	-	-	
1800	2195	2070	70	44	M64	1829,0	-	-	-	-	90	90	-	-	-	-	-	-	-	-	1920	20	-	-	
2000	2425	2300	70	48	M64	2032,0	-	-	-	-	96	96	-	-	-	-	-	-	-	-	2150	20	-	-	

* For flanges type 21 the outside hub diameter approximately corresponds to the outside pipe diameter.

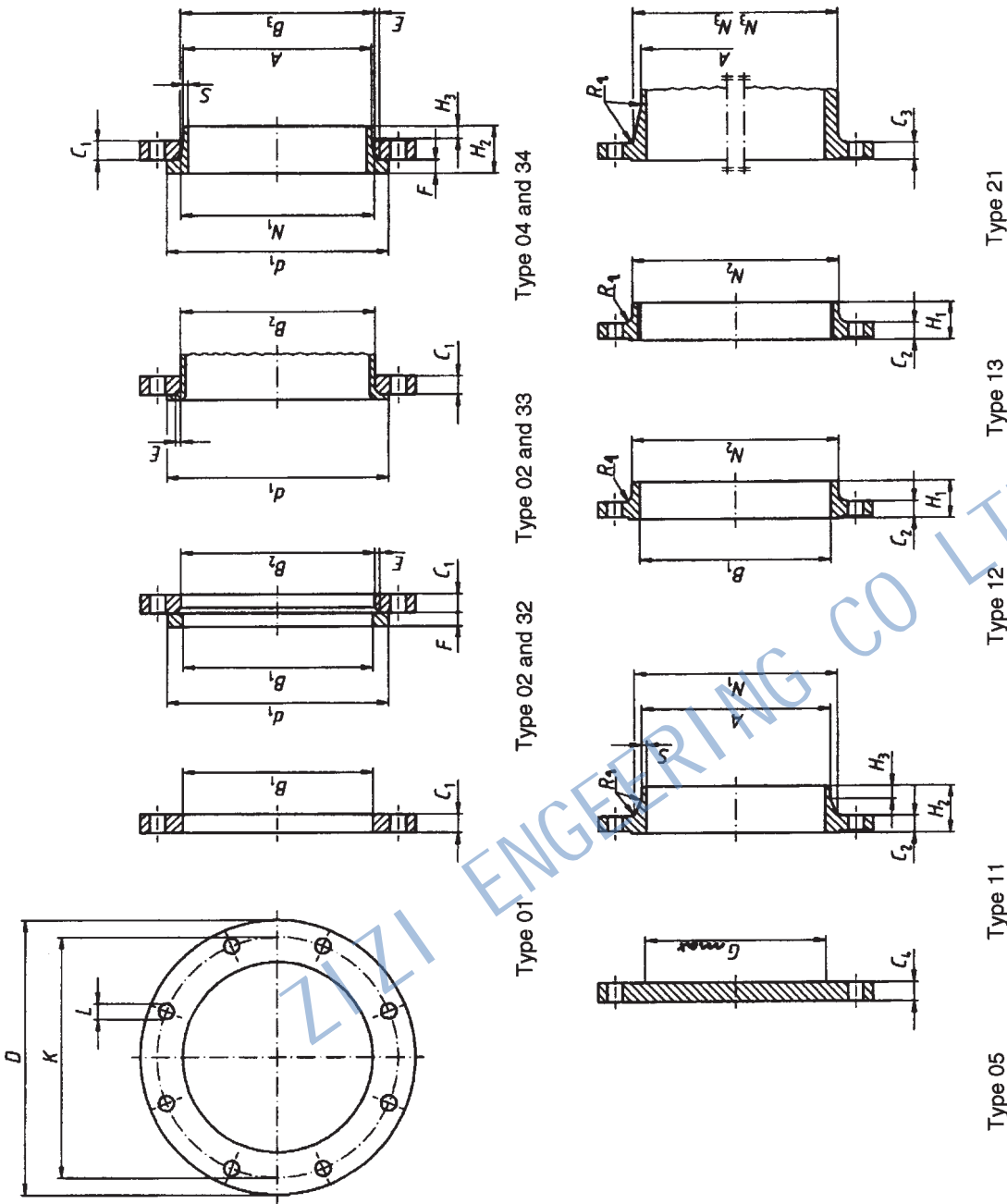

This diagram illustrates the arrangement but not necessarily the correct number of bolt holes.

Refer to the column "Bolting Number" in table 11 for the actual number.

NOTE 1 Dimensions M_1 , M_2 , and M_3 are measured at the intersection of the hub draft angle and the back face of the flange.

NOTE 2 For dimensions d_1 see table 4.

NOTE 3 For dimensions G_{max} refer to NOTE 1 of 5.6.1.

NOTE 4 Type 33; lapped pipe end without determination of thickness.

Figure 10 - Dimensions of PN 40 flanges

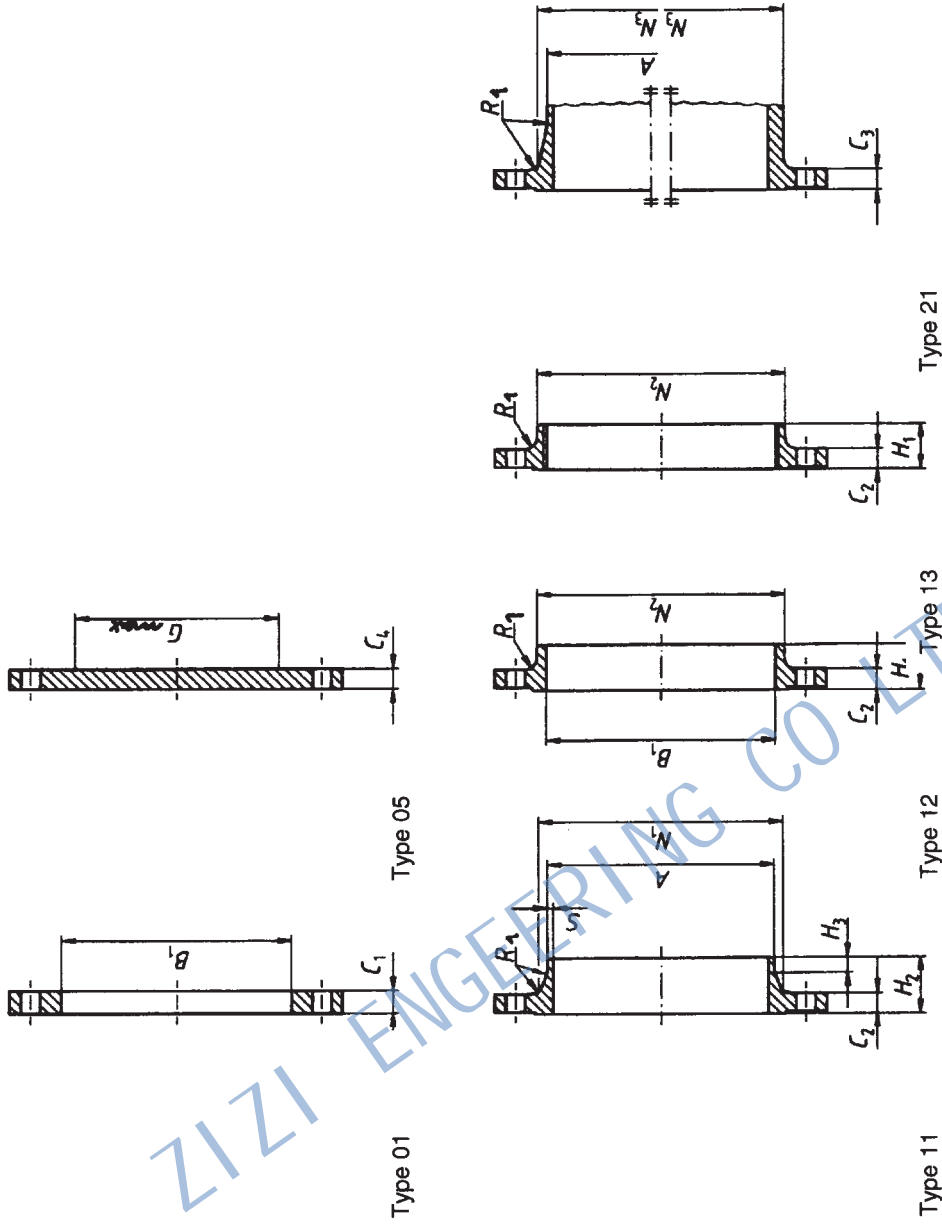
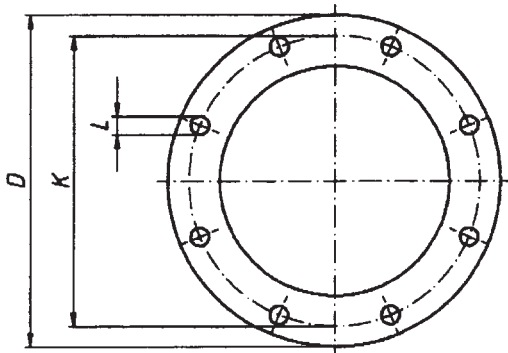

This diagram illustrates the arrangement but not necessarily the correct number of bolt holes.
 Refer to the column "Bolting Number" in table 12 for the actual number.

NOTE 1 Dimensions N_1 , N_2 and N_3 are measured at the intersections of the hub draft angle and the back face of the flange.

NOTE 2 For dimension G_{max} refer to NOTE 1 of 5.6.1.

Figure 11 - Dimensions of PN 63 flanges

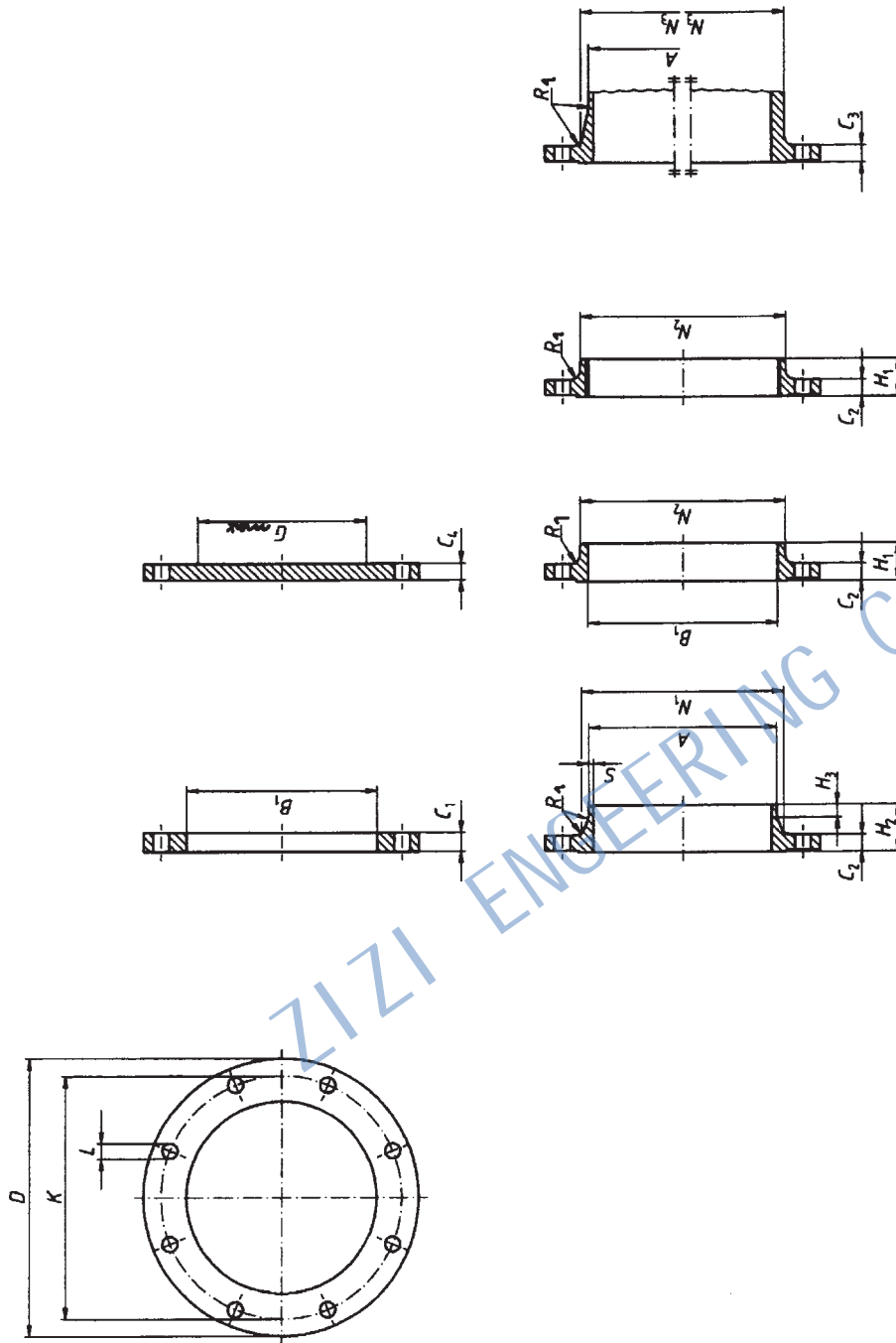

NOTE 1 Dimensions N_1 , N_2 and N_3 are measured at the intersections of the hub draft angle and the back face of the flange.
 NOTE 2 For dimension G_{max} refer to NOTE 1 of 5.6.1.

Figure 12 - Dimensions of PN 100 flanges

Table 14 - Tolerances

Dimension	Flange Type	Size	Tolerance Mm
Outside diameter of neck A	11, 21, 34	≤ DN 125	+3,0 0
		> DN 125 ≤ DN 1200	+4,5 0
		> DN 1200	+6,0 0
Bore diameter B_1, B_2, B_3	01, 02, 04, 12, 32	≤ DN 100	+0,5 0
		> DN 100 ≤ DN 400	+1,0 0
		> DN 400 ≤ DN 600	+1,5 0
		> DN 600	+3,0 0
Outside diameter D	21	≤ DN 250 > DN 250 ≤ DN 500 > DN 500 ≤ DN 800 > DN 800 ≤ DN 1200 > DN 1200 ≤ DN 1600 > DN 1600 ≤ DN 2000 > DN 2000	± 4,0 ± 5,0 ± 6,0 ± 7,0 ± 8,0 ± 10,0 ± 12,0
	All other types	≤ DN 150 > DN 150 ≤ DN 500 > DN 500 ≤ DN 1200 > DN 1200 ≤ DN 1800 > DN 1800	± 2,0 ± 3,0 ± 5,0 ± 7,0 ± 10,0
Length through hub H_1, H_2, H_3	11, 12, 13	≤ DN 80 > DN 80 ≤ DN 250 > DN 250	± 1,5 ± 2,0 ± 3,0
Neck diameter N_1, N_2, N_3	11, 21, 34	≤ DN 50 > DN 50 ≤ DN 150 > DN 150 ≤ DN 300 > DN 300 ≤ DN 600 > DN 600 ≤ DN 1200	0 -2,0 0 -4,0 0 -6,0 0 -8,0 0 -10,0
	12, 13	≤ DN 50 > DN 50 ≤ DN 150 > DN 150 ≤ DN 300 > DN 300 ≤ DN 600 > DN 600 ≤ DN 1200 > DN 1200 ≤ DN 1800 > DN 1800	+1,0 0 +2,0 0 +4,0 0 +8,0 0 +12,0 0 +16,0 0 +20,0 0

(continued)

Table 14 (concluded)

Dimension		Flange type	Size	Tolerance mm
Flange thickness C_1, C_2, C_3, C_4		All types (machined on both faces)	≤ 18 mm thickness > 18 mm ≤ 50 mm thickness > 50 mm thickness	± 1,0 ± 1,5 ± 2,0
		All types (machined on front face only) Type 02 and 04 (unmachined)	≤ 18 mm thickness > 18 mm ≤ 50 mm thickness > 50 mm thickness	+2,0 -1,3 +4,0 -1,5 +7,0 -2,0
Facing diameter d_1		All types	≤ DN 250 > DN 250	+2,0 -1,0 +3,0 -1,0
Facing height f_1		All types (facing type B, D, F and G)	2 mm	0 -1,0
Facing height f_2		All types (facing types C, E and G)	All DN	+0,5 0
Facing height f_3		All types (facing types D and F)	All DN	+0,5 0
		All types (facing type H)	All DN	+0,2 0
Facing height f_4		All types (facing type H)	All DN	+0,5 0
Facing	W	All types	All DN	+0,5 0
	X			0 -0,5
	Y			+0,5 0
	Z			0 -0,5
Diameter of bolt circle K		All types	Bolt sizes M10 to M24	± 1,0
			Bolt sizes M27 to M45	± 1,5
Centre-to-centre of adjacent bolt holes		All types	Bolt sizes M10 to M24	± 1,0
			Bolt sizes M27 to M45	± 1,5
Eccentricity of machined facing diameters		All types	≤ DN 100	1,0
			> DN 100	2,0
Parallelism between bolting bearing surfaces and flange jointing faces		All types (machined bearing surfaces)	All DN	1°
		All types (unmachined bearing surfaces)		2°

Table 15 - Pressure/temperature (p/T) ratings for flanges made of ferritic steels

PN	Material group	Maximum allowable temperature TS in °C														
		RT ^a	100	150	200	250	300	350	400	425	450	475	500	510	520	530
		Maximum allowable pressure PS in bar ^b														
2,5	1E0	2,5	2,5	-	-	-	-	-	-	-	-	-	-	-	-	-
	1E1	2,5	2,0	1,9	1,7	1,5	1,3	-	-	-	-	-	-	-	-	-
	2E0	2,5	2,5	-	-	-	-	-	-	-	-	-	-	-	-	-
	3E0	2,5	2,2	2,0	1,9	1,8	1,6	1,5	1,4	-	-	-	-	-	-	-
	3E1	2,5	2,5	2,5	2,5	2,3	2,1	1,9	1,7	-	-	-	-	-	-	-
6	1E0	6,0	6,0	-	-	-	-	-	-	-	-	-	-	-	-	-
	1E1	6,0	4,8	4,5	4,1	3,6	3,1	-	-	-	-	-	-	-	-	-
	2E0	6,0	6,0	-	-	-	-	-	-	-	-	-	-	-	-	-
	3E0	6,0	5,6	5,2	4,7	4,3	3,9	3,6	3,5	-	-	-	-	-	-	-
	3E1	6,0	6,0	6,0	6,0	5,5	4,9	4,5	4,1	-	-	-	-	-	-	-
10	1E0	10,0	10,0	-	-	-	-	-	-	-	-	-	-	-	-	-
	1E1	10,0	8,0	7,5	6,9	6,0	5,2	-	-	-	-	-	-	-	-	-
	2E0	10,0	10,0	-	-	-	-	-	-	-	-	-	-	-	-	-
	3E0	10,0	9,3	8,7	7,8	7,1	6,4	6,0	5,8	4,5	-	-	-	-	-	-
	3E1	10,0	10,0	10,0	10,0	9,1	8,2	7,6	6,9	-	-	-	-	-	-	-
16	1E0	16,0	16,0	-	-	-	-	-	-	-	-	-	-	-	-	-
	1E1	16,0	12,8	11,9	11,0	9,7	8,3	-	-	-	-	-	-	-	-	-
	2E0	16,0	16,0	-	-	-	-	-	-	-	-	-	-	-	-	-
	3E0	16,0	14,9	13,9	12,4	11,4	10,3	9,6	9,2	-	-	-	-	-	-	-
	3E1	16,0	16,0	16,0	16,0	14,6	13,2	12,1	11,0	-	-	-	-	-	-	-
25	1E0	25,0	25,0	-	-	-	-	-	-	-	-	-	-	-	-	-
	1E1	25,0	20,0	18,7	17,2	15,1	13,0	-	-	-	-	-	-	-	-	-
	2E0	25,0	25,0	-	-	-	-	-	-	-	-	-	-	-	-	-
	3E0	25,0	23,3	21,7	19,4	17,8	16,1	15,0	14,4	-	-	-	-	-	-	-
	3E1	25,0	25,0	25,0	25,0	22,8	20,6	18,9	17,2	-	-	-	-	-	-	-
40	1E0	40,0	40,0	-	-	-	-	-	-	-	-	-	-	-	-	-
	1E1	40,0	32,0	29,9	27,6	24,2	20,8	-	-	-	-	-	-	-	-	-
	2E0	40,0	40,0	-	-	-	-	-	-	-	-	-	-	-	-	-
	3E0	40,0	37,3	34,7	30,2	28,4	25,8	24,0	23,1	-	-	-	-	-	-	-
	3E1	40,0	40,0	40,0	40,0	36,4	32,9	30,2	27,6	-	-	-	-	-	-	-
63	1E0	63,0	63,0	-	-	-	-	-	-	-	-	-	-	-	-	-
	1E1	63,0	50,4	47,0	43,4	38,1	32,8	-	-	-	-	-	-	-	-	-
	2E0	63,0	63,0	-	-	-	-	-	-	-	-	-	-	-	-	-
	3E0	63,0	58,8	54,6	47,6	44,8	40,6	37,8	36,4	-	-	-	-	-	-	-
	3E1	63,0	63,0	63,0	63,0	57,4	51,8	47,6	43,4	-	-	-	-	-	-	-
100	1E0	100,0	100,0	-	-	-	-	-	-	-	-	-	-	-	-	-
	1E1	100,0	80,0	74,7	68,9	60,4	52,0	-	-	-	-	-	-	-	-	-
	2E0	100,0	100,0	-	-	-	-	-	-	-	-	-	-	-	-	-
	3E0	100,0	93,3	86,7	75,6	71,1	64,4	60,0	57,8	-	-	-	-	-	-	-
	3E1	100,0	100,0	100,0	100,0	91,1	82,2	75,6	68,9	-	-	-	-	-	-	-

^a -10 °C to 50 °C.

^b 1bar = 100 kPa.

NOTE The p/T ratings apply only for flange types 05,11,12,13 and 21 having nominal sizes up to and including DN 600. The p/T ratings of all other flanges shall be agreed between the manufacturer and purchaser.

Table 16 - Pressure/temperature (p/T) ratings for flanges made using material groups 7EO to 9EO

PN	Material group	Maximum allowable temperature TS in °C											
		RT ^a	100	150	200	250	300	350	400	450	500	550	600
		Maximum allowable pressure PS in bar ^b											
2,5	7E0	2,5	2,5	-	-	-	-	-	-	-	-	-	-
	7E1	2,5	2,5	-	-	-	-	-	-	-	-	-	-
	7E2	2,5	2,5	-	-	-	-	-	-	-	-	-	-
	7E3	2,5	2,3	2,1	1,9	1,7	1,6	-	-	-	-	-	-
	8E0	2,5	2,5	-	-	-	-	-	-	-	-	-	-
	8E1	2,5	2,5	-	-	-	-	-	-	-	-	-	-
	8E2	2,5	2,5	2,4	2,2	2,0	1,6	1,4	1,2	-	-	-	-
	8E3	2,5	2,5	2,5	2,5	2,5	2,4	2,2	1,9	-	-	-	-
	9E0	2,5	2,5	2,5	2,5	2,5	2,5	2,5	2,5	2,5	2,5	1,4	0,7
6	7E0	6,0	6,0	-	-	-	-	-	-	-	-	-	-
	7E1	6,0	6,0	-	-	-	-	-	-	-	-	-	-
	7E2	6,0	6,0	-	-	-	-	-	-	-	-	-	-
	7E3	6,0	5,6	5,1	4,5	4,1	3,7	-	-	-	-	-	-
	8E0	6,0	6,0	-	-	-	-	-	-	-	-	-	-
	8E1	6,0	6,0	-	-	-	-	-	-	-	-	-	-
	8E2	6,0	6,0	5,8	5,2	4,7	3,9	3,4	2,9	-	-	-	-
	8E3	6,0	6,0	6,0	6,0	6,0	5,8	5,2	4,5	-	-	-	-
	9E0	6,0	6,0	6,0	6,0	6,0	6,0	6,0	6,0	6,0	6,0	3,4	1,6
10	7E0	10,0	10,0	-	-	-	-	-	-	-	-	-	-
	7E1	10,0	10,0	-	-	-	-	-	-	-	-	-	-
	7E2	10,0	10,0	-	-	-	-	-	-	-	-	-	-
	7E3	10,0	9,3	8,4	7,6	6,9	6,2	-	-	-	-	-	-
	8E0	10,0	10,0	-	-	-	-	-	-	-	-	-	-
	8E1	10,0	10,0	-	-	-	-	-	-	-	-	-	-
	8E2	10,0	10,0	9,6	8,7	7,9	6,5	5,6	4,8	-	-	-	-
	8E3	10,0	10,0	10,0	10,0	10,0	9,6	8,7	7,4	-	-	-	-
	9E0	10,0	10,0	10,0	10,0	10,0	10,0	10,0	10,0	10,0	10,0	5,7	2,6
16	7E0	16,0	16,0	-	-	-	-	-	-	-	-	-	-
	7E1	16,0	16,0	-	-	-	-	-	-	-	-	-	-
	7E2	16,0	16,0	-	-	-	-	-	-	-	-	-	-
	7E3	16,0	14,9	13,5	12,1	11,0	10,0	-	-	-	-	-	-
	8E0	16,0	16,0	-	-	-	-	-	-	-	-	-	-
	8E1	16,0	16,0	-	-	-	-	-	-	-	-	-	-
	8E2	16,0	16,0	15,4	13,9	12,6	10,5	9,0	7,7	-	-	-	-
	8E3	16,0	16,0	16,0	16,0	16,0	15,4	13,9	11,9	-	-	-	-
	9E0	16,0	16,0	16,0	16,0	16,0	16,0	16,0	16,0	16,0	16,0	9,1	4,2
25	7E0	25,0	25,0	-	-	-	-	-	-	-	-	-	-
	7E1	25,0	25,0	-	-	-	-	-	-	-	-	-	-
	7E2	25,0	25,0	-	-	-	-	-	-	-	-	-	-
	7E3	25,0	23,3	21,1	18,9	17,2	15,6	-	-	-	-	-	-
	8E0	25,0	25,0	-	-	-	-	-	-	-	-	-	-
	8E1	25,0	25,0	-	-	-	-	-	-	-	-	-	-
	8E2	25,0	25,0	24,0	21,8	19,7	16,3	14,1	12,0	-	-	-	-
	8E3	25,0	25,0	25,0	25,0	25,0	24,0	21,8	18,6	-	-	-	-
	9E0	25,0	25,0	25,0	25,0	25,0	25,0	25,0	25,0	25,0	25,0	14,2	6,6
40	7E0	40,0	40,0	-	-	-	-	-	-	-	-	-	-
	7E1	40,0	40,0	-	-	-	-	-	-	-	-	-	-
	7E2	40,0	40,0	-	-	-	-	-	-	-	-	-	-
	7E3	40,0	37,3	33,8	30,2	27,6	24,9	-	-	-	-	-	-
	8E0	40,0	40,0	-	-	-	-	-	-	-	-	-	-
	8E1	40,0	40,0	-	-	-	-	-	-	-	-	-	-
	8E2	40,0	40,0	38,4	34,8	31,5	26,1	22,6	19,2	-	-	-	-
	8E3	40,0	40,0	40,0	40,0	40,0	38,4	34,8	29,7	-	-	-	-
	9E0	40,0	40,0	40,0	40,0	40,0	40,0	40,0	40,0	40,0	40,0	28,2	10,5
63	7E0	63,0	63,0	-	-	-	-	-	-	-	-	-	-
	7E1	63,0	63,0	-	-	-	-	-	-	-	-	-	-
	7E2	63,0	63,0	-	-	-	-	-	-	-	-	-	-
	7E3	63,0	58,8	53,2	47,6	43,4	39,2	-	-	-	-	-	-
	8E0	63,0	63,0	-	-	-	-	-	-	-	-	-	-
	8E1	63,0	63,0	-	-	-	-	-	-	-	-	-	-
	8E2	63,0	63,0	60,5	54,9	49,6	41,2	35,6	30,2	-	-	-	-
	8E3	63,0	63,0	63,0	63,0	63,0	60,5	54,9	46,8	-	-	-	-
	9E0	63,0	63,0	63,0	63,0	63,0	63,0	63,0	63,0	63,0	63,0	35,8	16,5
100	7E0	100,0	100,0	-	-	-	-	-	-	-	-	-	-
	7E1	100,0	100,0	-	-	-	-	-	-	-	-	-	-
	7E2	100,0	100,0	-	-	-	-	-	-	-	-	-	-
	7E3	100,0	93,3	84,4	75,6	68,9	62,2	-	-	-	-	-	-
	8E0	100,0	100,0	-	-	-	-	-	-	-	-	-	-
	8E1	100,0	100,0	-	-	-	-	-	-	-	-	-	-
	8E2	100,0	100,0	96,0	87,1	78,7	65,3	56,4	48,0	-	-	-	-
	8E3	100,0	100,0	100,0	100,0	100,0	96,0	87,1	74,2	-	-	-	-
	9E0	100,0	100,0	100,0	100,0	100,0	100,0	100,0	100,0	100,0	100,0	56,9	26,2

^a -10 °C to 50 °C.

^b 1bar = 100 kPa.

NOTE The p/T ratings apply only for flange types 05,11,12,13 and 21 having nominal sizes up to and including DN 600.

The p/T ratings of all other flanges shall be agreed between the manufacturer and purchaser.

Table 17 - Pressure/temperature (p/T) ratings for flanges made of austenitic and austenitic-ferritic steels, based on 0,2 % proof stress

PN	Material group	Maximum allowable temperature TS in °C													
		RT ^a	50	100	150	200	250	300	350	400	450	500	550	600	
		Maximum allowable pressure PS in bar ^b													
2,5	10E0	2,3	1,9	1,7	1,6	1,4	1,3	1,2	1,2	1,1	1,1	1,0	-	-	
	10E1	2,5	2,5	2,3	1,9	1,7	1,6	1,5	1,4	1,4	1,4	1,3	1,3	1,0	
	11E0	2,2	1,9	1,7	1,6	1,4	1,3	1,2	1,2	1,1	1,1	1,0	-	-	
	12E0	2,2	2,1	2,0	1,8	1,7	1,6	1,5	1,4	1,4	1,4	1,3	1,3	1,0	
	13E0	2,1	2,1	1,8	1,7	1,5	1,4	1,3	1,3	1,2	1,2	1,1	-	-	
	13E1	2,5	2,5	2,4	2,2	1,9	1,8	1,7	1,7	1,6	1,6	1,5	-	-	
	14E0	2,3	2,2	1,9	1,8	1,6	1,5	1,4	1,3	1,3	1,3	1,2	1,2	1,1	
	15E0	2,3	2,3	2,1	2,0	1,8	1,7	1,6	1,6	1,5	1,5	1,4	1,4	1,3	
16E0	2,5	2,5	2,5	2,5	2,5	-	-	-	-	-	-	-	-	-	
6	10E0	5,6	4,7	4,1	3,7	3,4	3,1	2,9	2,8	2,6	2,5	2,5	-	-	
	10E1	6,0	6,0	5,5	4,7	4,2	3,9	3,6	3,5	3,3	3,3	3,2	3,0	2,4	
	11E0	5,3	4,7	4,1	3,7	3,4	3,1	2,9	2,8	2,6	2,5	2,5	-	-	
	12E0	5,3	5,1	4,7	4,4	4,1	3,9	3,6	3,5	3,3	3,3	3,2	3,1	2,3	
	13E0	5,1	4,9	4,4	4,0	3,7	3,4	3,2	3,0	2,9	2,8	2,7	-	-	
	13E1	6,0	6,0	5,7	5,2	4,7	4,4	4,1	4,0	3,9	3,8	3,7	-	-	
	14E0	5,5	5,2	4,7	4,2	3,9	3,6	3,4	3,2	3,1	3,0	2,9	2,8	2,7	
	15E0	5,6	5,5	5,1	4,7	4,4	4,1	3,9	3,7	3,6	3,5	3,5	3,3	3,2	
16E0	6,0	6,0	6,0	6,0	6,0	-	-	-	-	-	-	-	-	-	
10	10E0	9,3	7,8	6,9	6,2	5,6	5,2	4,9	4,6	4,4	4,2	4,1	-	-	
	10E1	10,0	10,0	9,1	7,8	7,0	6,4	6,0	5,8	5,6	5,4	5,3	5,1	4,0	
	11E0	8,9	7,8	6,9	6,2	5,6	5,2	4,9	4,6	4,4	4,2	4,1	-	-	
	12E0	8,9	8,4	7,8	7,3	6,9	6,4	6,0	5,8	5,6	5,4	5,3	5,1	3,8	
	13E0	8,4	8,2	7,3	6,7	6,1	5,6	5,3	5,0	4,8	4,6	4,4	-	-	
	13E1	10,0	10,0	9,6	8,7	7,8	7,3	6,9	6,7	6,4	6,3	6,1	-	-	
	14E0	9,1	8,7	7,8	7,0	6,4	6,0	5,6	5,3	5,1	5,0	4,9	4,7	4,4	
	15E0	9,3	9,1	8,4	7,8	7,3	6,9	6,4	6,2	6,0	5,9	5,8	5,6	5,3	
16E0	10,0	10,0	10,0	10,0	10,0	-	-	-	-	-	-	-	-	-	
16	10E0	14,9	12,4	11,0	10,0	9,0	8,4	7,8	7,4	7,0	6,8	6,5	-	-	
	10E1	16,0	16,0	14,6	12,4	11,2	10,3	9,7	9,2	8,9	8,7	8,5	8,1	6,3	
	11E0	14,2	12,4	11,0	10,0	9,0	8,4	7,8	7,4	7,0	6,8	6,5	-	-	
	12E0	14,2	13,5	12,5	11,7	11,0	10,3	9,7	9,2	8,9	8,7	8,5	8,2	6,1	
	13E0	13,5	13,2	11,7	10,7	9,7	9,0	8,5	8,0	7,7	7,4	7,1	-	-	
	13E1	16,0	16,0	15,3	13,9	12,4	11,7	11,0	10,7	10,3	10,1	9,8	-	-	
	14E0	14,6	13,9	12,4	11,2	10,3	9,6	9,0	8,5	8,2	8,0	7,8	7,5	7,1	
	15E0	14,9	14,6	13,5	12,5	11,7	11,0	10,3	10,0	9,6	9,5	9,2	8,9	8,5	
16E0	16,0	16,0	16,0	16,0	16,0	-	-	-	-	-	-	-	-	-	
25	10E0	23,3	25,0	22,8	19,4	17,4	16,1	15,1	14,4	13,9	13,6	13,2	-	-	
	10E1	25,0	19,4	17,2	15,6	14,1	13,1	12,2	11,6	10,9	10,6	10,2	-	-	
	11E0	22,2	21,1	19,6	18,3	17,2	16,1	15,1	14,4	13,9	13,6	13,2	9,8	7,6	
	12E0	22,2	21,1	19,6	18,3	17,2	16,1	15,1	14,4	13,9	13,6	13,2	12,8	9,6	
	13E0	21,1	25,0	23,9	21,7	19,4	18,3	17,2	16,7	16,1	15,8	15,3	-	-	
	13E1	22,8	21,7	19,4	17,6	16,1	15,0	14,1	13,3	12,8	12,6	12,2	-	-	
	14E0	22,8	22,8	21,1	19,6	18,3	17,2	16,1	15,6	15,0	14,8	14,4	13,9	13,3	
	15E0	23,3	22,8	21,1	19,6	18,3	17,2	16,1	15,6	15,0	14,8	14,4	13,9	13,3	
16E0	25,0	25,0	25,0	25,0	25,0	-	-	-	-	-	-	-	-	-	
40	10E0	37,3	31,1	27,6	24,9	22,6	21,0	19,6	18,5	17,4	16,9	16,4	-	-	
	10E1	40,0	40,0	36,4	31,1	27,9	25,8	24,2	23,1	22,2	21,7	21,2	20,3	15,8	
	11E0	35,6	31,1	27,6	24,9	22,6	21,0	19,6	18,5	17,4	16,9	16,4	-	-	
	12E0	35,6	33,8	31,3	29,3	27,6	25,8	24,2	23,1	22,2	21,7	21,2	20,4	15,3	
	13E0	33,8	32,9	29,3	26,7	24,4	22,6	21,2	20,1	19,2	18,5	17,8	-	-	
	13E1	40,0	40,0	38,2	34,7	31,1	29,3	27,6	26,7	25,8	25,2	24,5	-	-	
	14E0	36,4	34,7	31,1	28,1	25,8	24,0	22,6	21,3	20,4	20,1	19,6	18,7	17,8	
	15E0	37,3	36,4	33,8	31,3	29,3	27,6	25,8	24,9	24,0	23,6	23,1	22,2	21,3	
16E0	40,0	40,0	40,0	40,0	40,0	-	-	-	-	-	-	-	-	-	
63	10E0	58,8	49,0	43,4	39,2	35,6	33,0	30,8	29,1	27,4	26,6	25,8	-	-	
	10E1	63,0	63,0	57,4	49,0	44,0	40,6	38,1	36,4	35,0	34,2	33,3	31,9	24,9	
	11E0	56,0	49,0	43,4	39,2	35,6	33,0	30,8	29,1	27,4	26,6	25,8	-	-	
	12E0	56,0	53,2	49,3	46,2	43,4	40,6	38,1	36,4	35,0	34,2	33,3	32,2	24,1	
	13E0	53,2	51,8	46,2	42,0	38,4	35,6	33,3	31,6	30,2	29,1	28,0	-	-	
	13E1	63,0	63,0	60,2	54,6	49,0	46,2	43,4	42,0	40,6	39,8	38,6	-	-	
	14E0	57,4	54,6	49,0	44,2	40,6	37,8	35,6	33,6	32,2	31,6	30,8	29,4	28,0	
	15E0	58,8	57,4	53,2	49,3	46,2	43,4	40,6	39,2	37,8	37,2	36,4	35,0	33,6	
16E0	63,0	63,0	63,0	63,0	63,0	-	-	-	-	-	-	-	-	-	
100	10E0	93,3	77,8	68,9	62,2	56,4	52,4	48,9	46,2	43,6	42,2	40,9	-	-	
	10E1	100,0	100,0	91,1	77,8	69,8	64,4	60,4	57,8	55,6	54,2	52,9	50,7	39,6	
	11E0	88,9	77,8	68,9	62,2	56,4	52,4	48,9	46,2	43,6	42,2	40,9	-	-	
	12E0	88,9	84,4	78,2	73,3	68,9	64,4	60,4	57,8	55,6	54,2	52,9	51,1	38,2	
	13E0	84,4	82,2	73,3	66,7	60,9	56,4	52,9	50,2	48,0	46,2	44,4	-	-	
	13E1	100,0	100,0	95,6	86,7	77,8	73,3	68,9	66,7	64,4	63,1	61,3	-	-	
	14E0	91,1	86,7	77,8	70,2	64,4	60,0	56,4	53,3	51,1	50,2	48,9	46,7	44,4	
	15E0	93,3	91,1	84,4	78,2	73,3	68,9	64,4	62,2	60,0	59,1	57,8	55,6	53,3	
16E0	100,0	100,0	100,0	100,0	100,0	-	-	-	-	-	-	-	-	-	

^a -10 °C to 50 °C.

^b 1bar = 100 kPa.

NOTE The p/T ratings apply only for flange types 05,11,12,13 and 21 having nominal sizes up to and including DN 600.

The p/T ratings of all other flanges shall be agreed between the manufacturer and purchaser.

Table 18 - Pressure/temperature (p/T) ratings for flanges made of austenitic and austenitic-ferritic steels, 1 % proof stress

PN	Material group	Maximum allowable temperature TS in °C												
		RT ^a	50	100	150	200	250	300	350	400	450	500	550	600
		Maximum allowable pressure PS in bar ^b												
2,5	10E0	2,5	2,3	2,1	1,9	1,7	1,6	1,5	1,4	1,4	1,4	1,3	-	-
	10E1	2,5	2,5	2,5	2,3	2,1	1,9	1,9	1,8	1,7	1,7	1,7	1,6	1,0
	11E0	2,5	2,3	2,1	1,9	1,7	1,6	1,5	1,4	1,4	1,4	1,3	1,3	0,8
	12E0	2,5	2,5	2,3	2,2	2,1	1,9	1,9	1,8	1,7	1,7	1,7	1,6	1,0
	13E0	2,5	2,4	2,2	2,0	1,8	1,7	1,6	1,5	1,5	1,5	1,4	-	-
	13E1	2,5	2,5	2,5	2,5	2,3	2,2	2,1	2,0	1,9	1,9	1,9	-	-
	14E0	2,5	2,5	2,3	2,1	1,9	1,8	1,7	1,7	1,6	1,6	1,5	1,5	1,3
	15E0	2,5	2,5	2,4	2,3	2,1	2,0	1,9	1,9	1,8	1,8	1,8	1,7	1,4
	16E0	-	-	-	-	-	-	-	-	-	-	-	-	-
6	10E0	6,0	5,6	5,1	4,5	4,1	3,9	3,6	3,4	3,3	3,3	3,2	-	-
	10E1	6,0	6,0	6,0	5,6	5,0	4,7	4,5	4,3	4,2	4,1	4,0	3,7	2,4
	11E0	6,0	5,6	5,1	4,5	4,1	3,9	3,6	3,4	3,3	3,3	3,2	3,1	2,0
	12E0	6,0	6,0	5,6	5,2	4,9	4,7	4,5	4,3	4,2	4,1	4,0	3,8	2,3
	13E0	6,0	5,9	5,3	4,8	4,4	4,1	3,9	3,7	3,6	3,5	3,4	-	-
	13E1	6,0	6,0	6,0	6,0	5,5	5,2	4,9	4,8	4,7	4,6	4,5	-	-
	14E0	6,0	6,0	5,6	5,1	4,7	4,4	4,1	4,0	3,8	3,8	3,7	3,6	3,1
	15E0	6,0	6,0	5,9	5,5	5,1	4,9	4,7	4,5	4,4	4,3	4,2	4,2	3,3
	16E0	-	-	-	-	-	-	-	-	-	-	-	-	-
10	10E0	10,0	9,3	8,4	7,6	6,9	6,4	6,0	5,7	5,6	5,5	5,3	-	-
	10E1	10,0	10,0	10,0	9,3	8,3	7,8	7,4	7,1	6,9	6,8	6,6	6,2	4,0
	11E0	10,0	9,3	8,4	7,6	6,9	6,4	6,0	5,7	5,6	5,5	5,3	5,1	3,3
	12E0	10,0	10,0	9,3	8,7	8,2	7,8	7,4	7,2	6,9	6,8	6,6	6,3	3,9
	13E0	10,0	9,8	8,9	8,0	7,3	6,8	6,4	6,2	6,0	5,8	5,7	-	-
	13E1	10,0	10,0	10,0	10,0	9,1	8,7	8,2	8,0	7,8	7,6	7,5	-	-
	14E0	10,0	10,0	9,3	8,4	7,8	7,3	6,9	6,7	6,4	6,3	6,2	6,0	5,2
	15E0	10,0	10,0	9,8	9,1	8,5	8,1	7,8	7,5	7,3	7,2	7,0	6,9	5,4
	16E0	-	-	-	-	-	-	-	-	-	-	-	-	-
16	10E0	16,0	14,9	13,5	12,1	11,0	10,3	9,6	9,2	8,9	8,7	8,5	-	-
	10E1	16,0	16,0	16,0	14,9	13,3	12,4	11,9	11,4	11,1	10,9	10,6	10,0	6,3
	11E0	16,0	14,9	13,5	12,1	11,0	10,3	9,6	9,2	8,9	8,7	8,5	8,2	5,3
	12E0	16,0	16,0	14,9	13,9	13,2	12,4	11,9	11,4	11,1	10,8	10,6	10,1	6,3
	13E0	16,0	15,6	14,2	12,8	11,7	10,9	10,3	9,9	9,6	9,3	9,1	-	-
	13E1	16,0	16,0	16,0	16,0	14,6	13,9	13,2	12,8	12,4	12,2	11,9	-	-
	14E0	16,0	16,0	14,9	13,5	12,4	11,7	11,0	10,7	10,2	10,1	9,9	9,5	8,2
	15E0	16,0	16,0	15,6	14,6	13,7	13,0	12,4	12,0	11,7	11,4	11,2	11,1	8,7
	16E0	-	-	-	-	-	-	-	-	-	-	-	-	-
25	10E0	25,0	23,3	21,1	18,9	17,2	16,1	15,0	14,3	13,9	13,7	13,3	-	-
	10E1	25,0	25,0	25,0	23,3	20,8	19,4	18,6	17,8	17,3	17,0	16,6	15,6	9,9
	11E0	25,0	23,3	21,1	18,9	17,2	16,1	15,0	14,3	13,9	13,7	13,3	12,8	8,3
	12E0	25,0	25,0	23,3	21,7	20,6	19,4	18,6	17,9	17,3	16,9	16,6	15,8	9,8
	13E0	25,0	24,4	22,2	20,0	18,3	17,0	16,1	15,4	15,0	14,6	14,2	-	-
	13E1	25,0	25,0	25,0	25,0	22,8	21,7	20,6	20,0	19,4	19,1	18,7	-	-
	14E0	25,0	25,0	23,3	21,1	19,1	18,3	17,2	16,7	16,0	15,8	15,4	14,9	12,9
	15E0	25,0	25,0	24,4	22,8	21,3	20,3	19,4	18,8	18,2	17,9	17,6	17,3	13,6
	16E0	-	-	-	-	-	-	-	-	-	-	-	-	-
40	10E0	40,0	37,3	33,8	30,2	27,6	25,8	24,0	22,9	22,2	21,9	21,3	-	-
	10E1	40,0	40,0	40,0	37,3	33,2	31,1	29,7	28,4	27,7	27,2	26,5	24,9	15,8
	11E0	40,0	37,3	33,8	30,2	27,6	25,8	24,0	22,9	22,2	21,9	21,3	20,4	13,3
	12E0	40,0	40,0	37,3	34,7	32,9	31,1	29,7	28,6	27,7	27,0	26,5	25,2	15,6
	13E0	40,0	39,1	35,6	32,0	29,3	27,2	25,8	24,7	24,0	23,3	22,8	-	-
	13E1	40,0	40,0	40,0	40,0	36,4	34,7	32,9	32,0	31,1	30,6	29,9	-	-
	14E0	40,0	40,0	37,3	33,8	31,1	29,3	27,6	26,7	25,6	25,2	24,7	23,8	20,6
	15E0	40,0	40,0	39,1	36,4	34,1	32,5	31,1	30,0	29,2	28,6	28,1	27,7	21,7
	16E0	-	-	-	-	-	-	-	-	-	-	-	-	-
63	10E0	63,0	58,8	53,2	47,6	43,4	40,6	37,8	36,1	35,0	34,4	33,6	-	-
	10E1	63,0	63,0	63,0	58,8	52,4	49,0	46,8	44,8	43,7	42,8	41,7	39,2	24,9
	11E0	63,0	58,8	53,2	47,6	43,4	40,6	37,8	36,1	35,0	34,4	33,6	32,2	21,0
	12E0	63,0	63,0	58,8	54,6	51,8	49,0	46,8	45,1	43,7	42,6	41,7	39,8	24,6
	13E0	63,0	61,6	56,0	50,4	46,2	42,8	40,6	38,9	37,8	36,7	35,8	-	-
	13E1	63,0	63,0	63,0	63,0	57,4	54,6	51,8	50,4	49,0	48,2	47,0	-	-
	14E0	63,0	63,0	58,8	53,2	49,0	46,2	43,4	42,0	40,3	39,8	38,9	37,5	32,5
	15E0	63,0	63,0	61,6	57,4	53,8	51,2	49,0	47,3	45,9	45,1	44,2	43,7	34,2
	16E0	-	-	-	-	-	-	-	-	-	-	-	-	-
100	10E0	100,0	93,3	84,4	75,6	68,9	64,4	60,0	57,3	55,6	54,7	53,3	-	-
	10E1	100,0	100,0	100,0	93,3	83,1	77,8	74,2	71,1	69,3	68,0	66,2	62,2	39,6
	11E0	100,0	93,3	84,4	75,6	68,9	64,4	60,0	57,3	55,6	54,7	53,3	51,1	33,3
	12E0	100,0	100,0	93,3	86,7	82,2	77,8	74,2	71,6	69,3	67,6	66,2	63,1	39,1
	13E0	100,0	97,8	88,9	80,0	73,3	68,0	64,4	61,8	60,0	58,2	56,9	-	-
	13E1	100,0	100,0	100,0	100,0	91,1	86,7	82,2	80,0	77,8	76,4	74,7	-	-
	14E0	100,0	100,0	93,3	84,4	77,8	73,3	68,9	66,7	64,0	63,1	61,8	59,6	51,6
	15E0	100,0	100,0	97,8	91,1	85,3	81,3	77,8	75,1	72,9	71,6	70,2	69,3	54,2
	16E0	-	-	-	-	-	-	-	-	-	-	-	-	-

^a -10 °C to 50 °C.

^b 1 bar = 100 kPa.

NOTE The p/T ratings apply only for flange types 05, 11, 12, 13 and 21 having nominal sizes up to and including DN 600.

The p/T ratings of all other flanges shall be agreed between manufacturer and purchaser.

Table 19 - Pressure/temperature (p/T) ratings for flanges made using material groups 1C1 to 1C14

PN	Material group	Maximum allowable temperature TS in °C																					
		RT ^a	50	100	150	200	250	300	350	375	400	425	450	475	500	510	520	530	540	550	575	600	
		Maximum allowable pressure PS in bar ^b																					
2,5	1C1	2,5	2,5	2,5	2,4	2,3	2,2	2,0	2,0	1,9	1,6	1,4	0,9	0,6	0,4	-	-	-	-	-	-	-	
	1C2	2,5	2,5	2,5	2,5	2,5	2,5	2,3	2,2	2,1	1,6	1,4	0,9	0,6	0,4	-	-	-	-	-	-	-	
	1C3	2,5	2,5	2,4	2,3	2,3	2,1	2,0	1,9	1,8	1,5	1,3	0,9	0,6	0,4	-	-	-	-	-	-	-	
	1C4	2,3	2,2	2,0	2,0	1,9	1,8	1,7	1,6	1,6	1,4	1,2	0,9	0,6	0,4	-	-	-	-	-	-	-	
	1C5	2,5	2,5	2,5	2,4	2,3	2,2	2,2	2,1	2,0	1,8	1,8	1,7	1,6	1,1	-	-	-	-	-	-	-	
	1C7	2,5	2,5	2,5	2,5	2,5	2,5	2,4	2,3	2,2	2,0	2,0	1,9	1,7	1,3	1,0	0,9	0,7	0,6	0,6	-	-	
	1C9	2,5	2,5	2,5	2,5	2,5	2,5	2,4	2,3	2,3	2,2	2,2	2,1	1,7	1,2	1,0	0,9	0,8	0,7	0,6	0,4	0,2	
	1C10	2,5	2,5	2,5	2,5	2,5	2,5	2,5	2,5	2,5	2,4	2,4	2,3	1,8	1,4	1,2	1,1	0,9	0,8	0,7	0,5	0,3	
	1C13	2,5	2,5	2,5	2,5	2,5	2,5	2,5	2,5	2,5	2,4	2,4	2,3	2,2	1,5	1,0	0,9	0,8	0,7	0,6	0,5	0,4	0,3
	1C14	2,5	2,5	2,5	2,5	2,5	2,5	2,5	2,5	2,5	2,5	2,5	2,5	2,1	1,4	1,2	1,1	0,9	0,8	0,7	0,5	0,3	
6	1C1	6,0	6,0	6,0	5,8	5,6	5,4	5,0	4,7	4,6	4,0	3,3	2,3	1,5	1,0	-	-	-	-	-	-	-	
	1C2	6,0	6,0	6,0	6,0	6,0	6,0	5,5	5,3	5,1	4,0	3,3	2,3	1,5	1,0	-	-	-	-	-	-	-	
	1C3	6,0	6,0	5,8	5,7	5,5	5,2	4,8	4,6	4,5	3,8	3,1	2,3	1,5	1,0	-	-	-	-	-	-	-	
	1C4	5,5	5,4	5,0	4,8	4,7	4,5	4,1	4,0	3,9	3,5	3,0	2,2	1,5	1,0	-	-	-	-	-	-	-	
	1C5	6,0	6,0	6,0	5,8	5,6	5,4	5,3	5,1	4,9	4,4	4,3	4,2	3,8	2,8	-	-	-	-	-	-	-	
	1C7	6,0	6,0	6,0	6,0	6,0	6,0	5,8	5,6	5,4	4,8	4,8	4,7	4,2	3,1	2,5	2,2	1,8	1,6	1,4	-	-	
	1C9	6,0	6,0	6,0	6,0	6,0	6,0	5,8	5,6	5,5	5,4	5,3	5,1	4,1	2,9	2,5	2,2	1,9	1,6	1,4	1,0	0,7	
	1C10	6,0	6,0	6,0	6,0	6,0	6,0	6,0	6,0	6,0	5,9	5,8	5,7	4,3	3,3	3,0	2,7	2,3	2,0	1,7	1,2	0,8	
	1C13	6,0	6,0	6,0	6,0	6,0	6,0	6,0	6,0	6,0	5,9	5,8	5,6	5,4	3,6	2,4	2,2	1,9	1,7	1,5	1,4	1,0	0,7
	1C14	6,0	6,0	6,0	6,0	6,0	6,0	6,0	6,0	6,0	6,0	6,0	6,0	5,2	3,5	3,0	2,6	2,3	1,9	1,7	1,2	0,8	
10	1C1	10,0	10,0	10,0	9,7	9,4	9,0	8,3	7,9	7,7	6,7	5,5	3,8	2,6	1,7	-	-	-	-	-	-	-	
	1C2	10,0	10,0	10,0	10,0	10,0	10,0	9,3	8,8	8,5	6,7	5,5	3,8	2,6	1,7	-	-	-	-	-	-	-	
	1C3	10,0	10,0	9,7	9,4	9,2	8,7	8,1	7,7	7,5	6,3	5,3	3,8	2,6	1,7	-	-	-	-	-	-	-	
	1C4	9,1	9,0	8,3	8,1	7,9	7,5	6,9	6,6	6,5	5,9	5,0	3,8	2,6	1,7	-	-	-	-	-	-	-	
	1C5	10,0	10,0	10,0	9,6	9,3	9,1	8,8	8,5	8,3	7,4	7,2	7,0	6,4	4,6	-	-	-	-	-	-	-	
	1C7	10,0	10,0	10,0	10,0	10,0	10,0	9,72	9,4	9,0	8,0	8,0	7,8	7,1	5,1	4,2	3,6	3,1	2,6	2,4	-	-	
	1C9	10,0	10,0	10,0	10,0	10,0	10,0	9,72	9,4	9,2	9,0	8,8	8,6	6,8	4,9	4,2	3,7	3,2	2,8	2,4	1,7	1,1	
	1C10	10,0	10,0	10,0	10,0	10,0	10,0	10,0	10,0	10,0	9,9	9,7	9,5	7,3	5,5	5,0	4,4	3,9	3,4	2,9	2,0	1,3	
	1C13	10,0	10,0	10,0	10,0	10,0	10,0	10,0	10,0	9,9	9,7	9,4	9,1	6,0	4,1	3,6	3,3	2,9	2,6	2,3	1,7	1,2	
	1C14	10,0	10,0	10,0	10,0	10,0	10,0	10,0	10,0	10,0	10,0	10,0	10,0	8,7	5,9	5,0	4,4	3,8	3,3	2,9	2,0	1,4	
16	1C1	16,0	16,0	16,0	15,6	15,1	14,4	13,4	12,8	12,4	10,8	8,9	6,2	4,2	2,7	-	-	-	-	-	-	-	
	1C2	16,0	16,0	16,0	16,0	16,0	16,0	14,9	14,2	13,7	10,8	8,9	6,2	4,2	2,7	-	-	-	-	-	-	-	
	1C3	16,0	16,0	15,6	15,2	14,7	14,0	13,0	12,4	12,1	10,1	8,4	6,1	4,2	2,7	-	-	-	-	-	-	-	
	1C4	14,7	14,4	13,4	13,0	12,6	12,0	11,2	10,7	10,5	9,4	8,0	6,0	4,2	2,7	-	-	-	-	-	-	-	
	1C5	16,0	16,0	16,0	15,5	15,0	14,6	14,2	13,7	13,3	11,9	11,6	11,3	10,4	7,4	-	-	-	-	-	-	-	
	1C7	16,0	16,0	16,0	16,0	16,0	16,0	15,5	15,0	14,5	12,9	12,9	12,6	11,4	8,3	6,7	5,8	5,0	4,2	3,9	-	-	
	1C9	16,0	16,0	16,0	16,0	16,0	16,0	15,5	15,0	14,8	14,5	14,1	13,8	11,0	7,9	6,8	6,0	5,2	4,5	3,9	2,7	1,8	
	1C10	16,0	16,0	16,0	16,0	16,0	16,0	16,0	16,0	16,0	15,9	15,6	15,3	11,7	8,9	8,0	7,1	6,2	5,4	4,7	3,2	2,1	
	1C13	16,0	16,0	16,0	16,0	16,0	16,0	16,0	16,0	16,0	15,9	15,6	15,1	14,6	9,6	6,6	5,8	5,3	4,7	4,1	3,7	2,7	1,9
	1C14	16,0	16,0	16,0	16,0	16,0	16,0	16,0	16,0	16,0	16,0	16,0	16,0	14,0	9,4	8,0	7,1	6,1	5,3	4,6	3,2	2,2	

(continued)

Table 19 - (concluded)

PN	Material group	Maximum allowable temperature TS in °C																				
		RT ^a	50	100	150	200	250	300	350	375	400	425	450	475	500	510	520	530	540	550	575	600
		Maximum allowable pressure PS in bar ^b																				
25	1C1	25,0	25,0	25,0	24,4	23,7	22,5	20,9	20,0	19,4	16,9	14,0	9,7	6,5	4,2	-	-	-	-	-	-	-
	1C2	25,0	25,0	25,0	25,0	25,0	25,0	23,3	22,2	21,4	16,9	14,0	9,7	6,5	4,2	-	-	-	-	-	-	-
	1C3	25,0	25,0	24,4	23,7	23,0	21,9	20,4	19,4	18,8	15,9	13,3	9,6	6,5	4,2	-	-	-	-	-	-	-
	1C4	23,0	22,5	20,9	20,4	19,7	18,8	17,5	16,7	16,5	14,8	12,6	9,5	6,5	4,2	-	-	-	-	-	-	-
	1C5	25,0	25,0	25,0	24,2	23,4	22,8	22,1	21,4	20,8	18,6	18,2	17,7	16,2	11,7	-	-	-	-	-	-	-
	1C7	25,0	25,0	25,0	25,0	25,0	25,0	24,3	23,5	22,7	20,1	20,1	19,7	17,9	13,0	10,6	9,2	7,8	6,6	6,1	-	-
	1C9	25,0	25,0	25,0	25,0	25,0	25,0	24,3	23,5	23,1	22,7	22,1	21,5	17,1	12,5	10,7	9,4	8,2	7,0	6,1	4,2	2,9
	1C10	25,0	25,0	25,0	25,0	25,0	25,0	25,0	25,0	25,0	24,8	24,4	23,9	18,3	14,0	12,6	11,2	9,8	8,5	7,4	5,1	3,3
	1C13	25,0	25,0	25,0	25,0	25,0	25,0	25,0	25,0	24,9	24,3	23,6	22,8	15,1	10,4	9,1	8,2	7,3	6,5	5,8	4,3	3,0
	1C14	25,0	25,0	25,0	25,0	25,0	25,0	25,0	25,0	25,0	25,0	25,0	25,0	21,9	14,8	12,6	11,2	9,6	8,2	7,2	5,0	3,4
40	1C1	40,0	40,0	40,0	39,1	37,9	36,0	33,5	31,9	31,1	27,0	22,4	15,6	10,5	6,8	-	-	-	-	-	-	-
	1C2	40,0	40,0	40,0	40,0	40,0	40,0	37,2	35,6	34,2	27,0	22,4	15,6	10,5	6,8	-	-	-	-	-	-	-
	1C3	40,0	40,0	39,0	38,0	36,9	35,1	32,6	31,1	30,1	25,4	21,2	15,4	10,5	6,8	-	-	-	-	-	-	-
	1C4	36,8	36,1	33,5	32,6	31,6	30,1	27,9	26,7	26,3	23,7	20,1	15,2	10,5	6,8	-	-	-	-	-	-	-
	1C5	40,0	40,0	40,0	38,7	37,4	36,5	35,4	34,3	33,3	29,8	29,1	28,3	26,0	18,7	-	-	-	-	-	-	-
	1C7	40,0	40,0	40,0	40,0	40,0	40,0	38,9	37,6	36,3	32,2	32,2	31,6	28,6	20,7	16,9	14,7	12,5	10,7	9,8	-	-
	1C9	40,0	40,0	40,0	40,0	40,0	40,0	38,9	37,6	36,9	36,2	35,4	34,5	27,4	19,9	17,1	15,1	13,1	11,3	9,8	6,8	4,7
	1C10	40,0	40,0	40,0	40,0	40,0	40,0	40,0	40,0	40,0	39,7	39,0	38,3	29,2	22,3	20,2	18,0	15,7	13,6	12,0	8,1	5,3
	1C13	40,0	40,0	40,0	40,0	40,0	40,0	40,0	40,0	39,8	38,9	37,8	36,4	24,1	16,6	14,7	13,3	11,8	10,4	9,3	6,9	4,8
	1C14	40,0	40,0	40,0	40,0	40,0	40,0	40,0	40,0	40,0	40,0	40,0	40,0	35,0	23,7	20,2	17,8	15,5	13,3	11,7	8,1	5,5
63	1C1	63,0	63,0	63,0	61,5	59,6	56,8	52,7	50,3	49,0	42,5	35,2	24,5	16,6	10,8	-	-	-	-	-	-	-
	1C2	63,0	63,0	63,0	63,0	63,0	63,0	58,7	56,0	53,8	42,5	35,2	24,5	16,6	10,8	-	-	-	-	-	-	-
	1C3	63,0	63,0	61,4	59,8	58,1	55,2	51,3	48,9	47,5	40,0	33,4	24,3	16,6	10,8	-	-	-	-	-	-	-
	1C4	57,9	56,8	52,7	51,3	49,8	47,4	44,0	42,1	41,5	37,4	31,7	24,0	16,6	10,8	-	-	-	-	-	-	-
	1C5	63,0	63,0	63,0	61,0	58,9	57,4	55,7	54,0	52,4	46,9	45,8	44,5	40,9	29,5	-	-	-	-	-	-	-
	1C7	63,0	63,0	63,0	63,0	63,0	63,0	61,2	59,2	57,2	50,7	50,7	49,7	45,0	32,7	26,6	23,2	19,8	16,8	15,4	-	-
	1C9	63,0	63,0	63,0	63,0	63,0	63,0	61,2	59,2	58,1	57,1	55,7	54,3	43,2	31,4	26,9	23,8	20,7	17,8	15,6	10,8	7,4
	1C10	63,0	63,0	63,0	63,0	63,0	63,0	63,0	63,0	63,0	62,5	61,5	60,3	46,0	35,2	31,9	28,3	24,8	21,4	18,8	12,9	8,4
	1C13	63,0	63,0	63,0	63,0	63,0	63,0	63,0	63,0	62,7	61,3	59,6	57,3	37,9	26,1	23,2	20,9	18,6	16,4	14,8	10,9	7,6
	1C14	63,0	63,0	63,0	63,0	63,0	63,0	63,0	63,0	63,0	63,0	63,0	63,0	55,1	37,3	31,9	28,1	24,3	20,9	18,4	12,8	8,7
100	1C1	100	100	100	97,7	94,7	90,1	83,6	79,8	77,8	67,5	55,9	38,9	26,3	17,1	-	-	-	-	-	-	-
	1C2	100	100	100	100	100	100	93,1	88,9	85,4	67,5	55,9	38,9	26,3	17,1	-	-	-	-	-	-	-
	1C3	100	100	97,4	94,9	92,2	87,6	81,4	77,7	75,3	63,4	53,1	38,5	26,3	17,1	-	-	-	-	-	-	-
	1C4	91,9	90,2	83,7	81,5	79,0	75,2	69,8	66,8	65,8	59,3	50,3	38,1	26,3	17,1	-	-	-	-	-	-	-
	1C5	100	100	100	96,8	93,5	91,2	88,5	85,7	83,2	74,4	72,8	70,7	64,9	46,8	-	-	-	-	-	-	-
	1C7	100	100	100	100	100	100	97,2	94,0	90,8	80,4	80,4	78,9	71,5	51,9	42,3	36,8	31,4	26,6	24,5	-	-
	1C9	100	100	100	100	100	100	97,2	94,0	92,3	90,6	88,4	86,2	68,6	49,9	42,7	37,8	32,8	28,2	24,7	17,1	11,8
	1C10	100	100	100	100	100	100	100	100	100	99,2	97,6	95,6	73,1	55,9	50,6	44,9	39,3	34,0	29,9	20,5	13,4
	1C13	100	100	100	100	100	100	100	100	99,6	97,3	94,6	91,0	60,2	41,4	36,8	33,1	29,5	26,1	23,4	17,3	12,1
	1C14	100	100	100	100	100	100	100	100	100	100	100	100	87,5	59,2	50,6	44,6	38,6	33,1	29,2	20,3	14,0

^a -10°C to 50 °C.

^b 1 bar = 100 kPa.

NOTE The p/T ratings apply only for flange types 05, 11, 12, 13 and 21 having nominal sizes up to and including DN 600.

The p/T ratings of all other flanges shall be agreed between manufacturer and purchaser.

Table 20 - Pressure ratings (p/T) ratings for PN flanges made using material groups 2C1 to 2C7

PN	Material Group	Maximum allowable temperature TS in °C																					
		RT ^a	50	100	150	200	250	300	350	375	400	425	450	475	500	510	520	530	540	550	575	600	
		Maximum allowable pressure PS in bar ^b																					
2,5	2C1	2,3	2,2	1,8	1,7	1,6	1,5	1,4	1,3	1,3	1,3	1,2	1,2	1,2	1,2	1,2	1,2	1,2	1,1	1,1	1,0	0,8	
	2C2	2,3	2,2	1,9	1,7	1,6	1,5	1,4	1,4	1,3	1,3	1,3	1,3	1,3	1,3	1,3	1,3	1,3	1,3	1,2	1,2	0,9	
	2C3	1,9	1,8	1,6	1,4	1,3	1,2	1,1	1,1	1,0	1,0	1,0	1,0	-	-	-	-	-	-	-	-	-	
	2C4	2,3	2,2	2,0	1,9	1,7	1,6	1,5	1,5	1,4	1,4	1,4	1,4	1,4	1,4	1,3	1,3	1,3	1,3	1,3	1,2	0,9	
	2C5	2,3	2,2	2,0	1,9	1,8	1,7	1,6	1,6	1,5	1,5	1,5	1,5	1,5	1,5	1,5	1,5	1,5	1,5	1,4	1,2	0,9	
	2C6	2,1	2,1	1,9	1,8	1,7	1,6	1,5	1,4	1,4	1,4	1,3	1,3	1,3	1,3	1,2	1,2	1,1	1,1	1,0	0,9	0,7	
	2C7	2,1	2,1	1,9	1,8	1,7	1,6	1,5	1,4	1,4	1,4	1,4	1,3	1,3	1,3	1,3	1,2	1,2	1,1	1,1	1,0	0,8	
6	2C1	5,5	5,3	4,5	4,1	3,8	3,6	3,4	3,2	3,2	3,1	3,0	3,0	2,9	2,9	2,9	2,9	2,8	2,8	2,7	2,4	1,9	
	2C2	5,5	5,3	4,6	4,2	3,9	3,7	3,5	3,3	3,3	3,2	3,2	3,2	3,1	3,1	3,1	3,1	3,1	3,1	3,1	2,8	2,3	
	2C3	4,6	4,4	3,8	3,4	3,1	2,9	2,8	2,6	2,6	2,5	2,5	2,4	-	-	-	-	-	-	-	-	-	
	2C4	5,5	5,3	4,9	4,5	4,2	4,0	3,7	3,6	3,5	3,5	3,4	3,4	3,3	3,3	3,3	3,3	3,3	3,3	3,2	2,9	2,3	
	2C5	5,5	5,4	5,0	4,7	4,4	4,1	3,9	3,8	3,7	3,7	3,7	3,7	3,7	3,7	3,7	3,7	3,6	3,6	3,6	3,5	3,0	2,3
	2C6	5,1	5,0	4,6	4,3	4,1	3,9	3,7	3,5	3,4	3,4	3,3	3,2	3,2	3,2	3,1	3,1	2,9	2,8	2,7	2,5	2,1	1,6
	2C7	5,1	5,0	4,6	4,3	4,1	3,9	3,7	3,5	3,4	3,4	3,3	3,2	3,2	3,2	3,1	3,1	3,0	2,9	2,8	2,7	2,5	1,9
10	2C1	9,1	8,8	7,5	6,8	6,3	6,0	5,6	5,4	5,4	5,2	5,1	5,0	4,9	4,9	4,8	4,8	4,8	4,7	4,6	4,0	3,2	
	2C2	9,1	8,9	7,8	7,1	6,6	6,1	5,8	5,6	5,5	5,4	5,4	5,3	5,3	5,2	5,2	5,2	5,2	5,1	5,1	4,7	3,8	
	2C3	7,6	7,4	6,3	5,7	5,3	4,9	4,6	4,4	4,3	4,2	4,2	4,1	-	-	-	-	-	-	-	-	-	
	2C4	9,1	8,9	8,1	7,5	7,0	6,6	6,3	6,0	5,9	5,8	5,7	5,7	5,6	5,6	5,5	5,5	5,5	5,5	5,4	4,9	3,9	
	2C5	9,1	9,0	8,3	7,8	7,3	6,9	6,6	6,4	6,3	6,2	6,2	6,2	6,1	6,1	6,1	6,1	6,1	6,0	5,8	5,0	3,8	
	2C6	8,5	8,3	7,6	7,2	6,8	6,5	6,1	5,9	5,8	5,6	5,5	5,4	5,3	5,2	5,1	4,9	4,7	4,5	4,2	3,5	2,8	
	2C7	8,5	8,4	7,6	7,2	6,8	6,5	6,2	5,9	5,8	5,7	5,5	5,4	5,3	5,2	5,2	5,0	4,8	4,7	4,6	4,1	3,2	
16	2C1	14,7	14,2	12,1	11,0	10,2	9,6	9,0	8,7	8,6	8,4	8,2	8,1	7,9	7,8	7,7	7,7	7,6	7,5	7,3	6,4	5,2	
	2C2	14,7	14,3	12,5	11,4	10,6	9,8	9,3	9,0	8,8	8,7	8,6	8,5	8,5	8,4	8,3	8,3	8,3	8,3	8,2	7,6	6,1	
	2C3	12,3	11,8	10,2	9,2	8,5	7,9	7,4	7,1	6,9	6,8	6,7	6,5	-	-	-	-	-	-	-	-	-	
	2C4	14,7	14,4	13,1	12,1	11,3	10,7	10,1	9,7	9,4	9,3	9,2	9,1	9,0	8,9	8,9	8,8	8,8	8,8	8,7	7,9	6,3	
	2C5	14,7	14,4	13,4	12,5	11,8	11,2	10,6	10,2	10,1	10,0	9,9	9,9	9,8	9,8	9,8	9,8	9,8	9,7	9,4	8,1	6,1	
	2C6	13,7	13,4	12,3	11,6	10,9	10,4	9,9	9,4	9,2	9,1	8,8	8,7	8,5	8,3	8,2	7,9	7,5	7,2	6,8	5,7	4,5	
	2C7	13,7	13,4	12,3	11,6	11,0	10,5	9,9	9,5	9,2	9,1	8,9	8,7	8,5	8,4	8,3	8,0	7,7	7,5	7,4	6,6	5,2	

(continued)

Table 20 - (concluded)

PN	Material group	Maximum allowable temperature TS in °C																				
		RT ^a	50	100	150	200	250	300	350	375	400	425	450	475	500	510	520	530	540	550	575	600
		Maximum allowable pressure PS in bar ^b																				
25	2C1	23,0	22,1	18,9	17,2	16,0	15,0	14,2	13,7	13,5	13,2	12,9	12,7	12,5	12,3	12,2	12,1	12,0	11,9	11,5	10,1	8,2
	2C2	23,0	22,3	19,5	17,8	16,5	15,5	14,6	14,1	13,8	13,6	13,5	13,4	13,3	13,2	13,1	13,1	13,0	13,0	12,9	12,0	9,6
	2C3	19,2	18,5	16,0	14,5	13,3	12,4	11,7	11,1	10,9	10,7	10,5	10,3	-	-	-	-	-	-	-	-	-
	2C4	23,0	22,5	20,4	19,0	17,7	16,7	15,8	15,2	14,8	14,6	14,4	14,3	14,1	14,0	13,9	13,9	13,8	13,8	13,6	12,4	9,8
	2C5	23,0	22,6	20,9	19,6	18,4	17,4	16,6	16,0	15,8	15,7	15,6	15,5	15,4	15,4	15,4	15,4	15,3	15,2	14,7	12,7	9,6
	2C6	21,5	21,0	19,2	18,1	17,1	16,3	15,5	14,8	14,5	14,2	13,9	13,6	13,3	13,1	12,9	12,4	11,8	11,2	10,7	8,9	7,0
	2C7	21,5	21,0	19,2	18,1	17,2	16,3	15,6	14,8	14,5	14,3	14,0	13,7	13,4	13,1	13,0	12,6	12,2	11,8	11,6	10,4	8,1
40	2C1	36,8	35,4	30,3	27,5	25,5	24,1	22,7	21,9	21,6	21,2	20,6	20,3	19,9	19,6	19,5	19,4	19,2	19,0	18,4	16,2	13,1
	2C2	36,8	35,6	31,3	28,5	26,4	24,7	23,4	22,6	22,1	21,8	21,6	21,4	21,2	21,0	21,0	20,9	20,8	20,8	20,7	19,1	15,5
	2C3	30,6	29,6	25,5	23,1	21,2	19,8	18,7	17,8	17,5	17,1	16,8	16,5	-	-	-	-	-	-	-	-	-
	2C4	36,8	35,9	32,7	30,3	28,4	26,7	25,3	24,2	23,7	23,4	23,1	22,8	22,6	22,4	22,3	22,2	22,1	22,0	21,8	19,9	15,8
	2C5	36,8	36,1	33,4	31,3	29,5	27,9	26,6	25,6	25,2	25,1	24,9	24,8	24,7	24,6	24,6	24,6	24,6	24,3	23,5	20,4	15,4
	2C6	34,3	33,6	30,7	29,0	27,4	26,0	24,8	23,7	23,2	22,8	22,2	21,8	21,3	20,9	20,7	19,8	18,9	18,0	17,1	14,4	11,3
	2C7	34,3	33,6	30,8	29,0	27,5	26,1	24,9	23,8	23,2	22,9	22,3	21,9	21,5	21,0	20,8	20,2	19,5	18,9	18,5	16,6	13,0
63	2C1	57,9	55,8	47,7	43,4	40,2	37,9	35,8	34,5	34,0	33,3	32,5	31,9	31,4	30,9	30,7	30,5	30,3	29,9	29,0	25,5	20,7
	2C2	57,9	56,1	49,2	44,9	41,6	38,9	36,9	35,5	34,9	34,4	34,0	33,7	33,5	33,2	33,0	32,9	32,8	32,7	32,6	30,2	24,4
	2C3	48,3	46,6	40,2	36,4	33,5	31,1	29,5	28,1	27,5	27,0	26,5	26,0	-	-	-	-	-	-	-	-	-
	2C4	57,9	56,6	51,4	47,8	44,7	42,0	39,8	38,2	37,4	36,8	36,3	36,0	35,6	35,3	35,1	35,0	34,9	34,7	34,4	31,3	24,8
	2C5	57,9	56,8	52,6	49,4	46,4	43,9	41,9	40,3	39,7	39,6	39,2	39,0	38,9	38,8	38,8	38,7	38,7	38,3	37,0	32,1	24,3
	2C6	54,1	52,9	48,3	45,7	43,1	41,0	39,0	37,3	36,6	35,9	35,0	34,3	33,6	32,9	32,6	31,2	29,8	28,3	26,9	22,6	17,8
	2C7	54,1	52,9	48,5	45,7	43,3	41,2	39,2	37,4	36,6	36,1	35,2	34,5	33,8	33,1	32,8	31,8	30,7	29,7	29,2	26,2	20,5
100	2C1	91,9	88,6	75,7	68,8	63,9	60,2	56,8	54,7	54,0	52,9	51,6	50,7	49,9	49,1	48,7	48,4	48,0	47,5	46,0	40,5	32,8
	2C2	91,9	89,1	78,1	71,3	66,0	61,8	58,5	56,4	55,3	54,5	54,0	53,4	53,1	52,6	52,4	52,2	52,1	51,9	51,7	47,9	38,7
	2C3	76,6	74,0	63,9	57,8	53,1	49,4	46,8	44,5	43,7	42,9	42,0	41,2	-	-	-	-	-	-	-	-	-
	2C4	91,9	89,8	81,6	75,9	70,9	66,7	63,2	60,6	59,3	58,5	57,6	57,1	56,5	56,0	55,8	55,6	55,3	55,1	54,5	49,7	39,4
	2C5	91,9	90,2	83,6	78,4	73,6	69,7	66,5	64,0	63,1	62,8	62,2	62,0	61,7	61,6	61,6	61,5	61,4	60,8	58,8	50,9	38,5
	2C6	85,8	83,9	76,7	72,5	68,4	65,0	61,9	59,2	58,0	56,9	55,6	54,4	53,3	52,2	51,8	49,5	47,2	45,0	42,7	35,9	28,2
	2C7	85,8	84,0	76,9	72,5	68,7	65,3	62,2	59,4	58,1	57,2	55,9	54,8	53,6	52,5	52,1	50,4	48,7	47,2	46,3	41,6	32,6

^a -10 °C to 50 °C.

^b 1 bar = 100 kPa.

NOTE The p/T ratings apply only for flange types 05, 11, 12, 13 and 21 having nominal sizes up to and including DN 600.

The p/T ratings of all other flanges shall be agreed between manufacturer and purchaser.

Table 21 - Minimum hub radius after back facing

Flange size	R_2 min. mm
Up to and including DN 50	2
Over DN 50 and up to including DN 200	3
Over DN 200	5

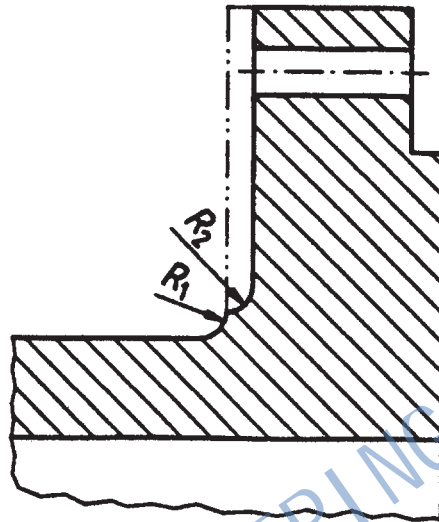

NOTE For dimensions of R_1 see tables 6 to 13.

Figure 13 - Minimum hub radius after back facing

Annex A
(normative)

Butt weld-end preparation

Unless otherwise specified, for flanges in accordance with this European Standard the welding end connections given in figures A.1 to A.3 shall be used. Additional types of welding ends are specified in EN 29692 and example of designs in EN 1708-1 and may be used by agreement between the equipment manufacturer and the flange manufacturer.

Dimensions in millimetres

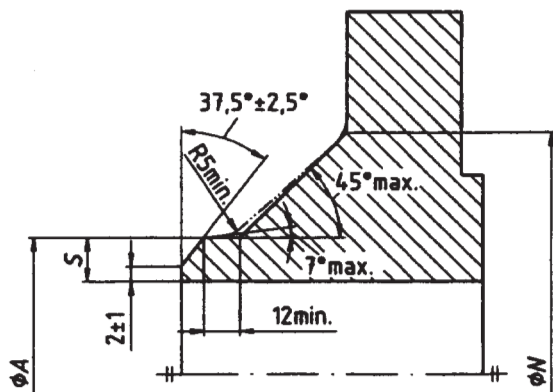

Figure A.1 – Welding end connection for wall thickness s 5 mm to 22,2 mm

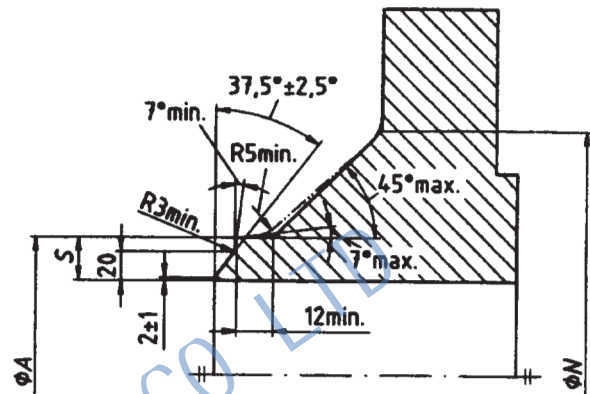

Figure A.2 – Welding end connection for wall thickness s \geq 22,2 mm

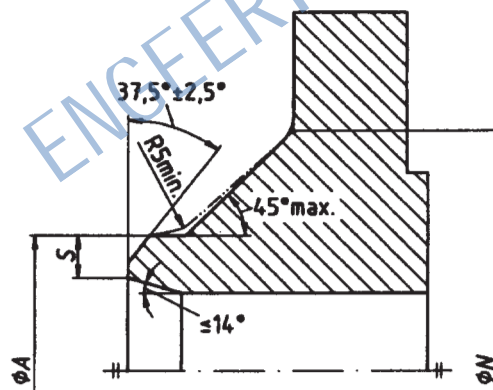

Figure A.3 - Permissible bevel design for unequal wall thickness

NOTE 1 For flanges required to connect to ferritic steel pipe of nominal wall thickness less than 4,8 mm the welding ends should be finished to a slight chamfer or be square, at the option of the manufacturer.

NOTE 2 For flanges required to connect to austenitic stainless steel pipe of nominal wall thickness 3,2 mm or less, the welding ends should be finished to a slight chamfer.

NOTE 3 The wall thickness of the flange, which connects to the pipe, should not be less than the pipe thickness or be more than 3 mm thicker.

Annex B
(informative)

Material groups

The material groups contain materials of similar chemical/mechanical properties and corrosion resistance in order to facilitate an equivalent application of materials in a group depending on pressure, temperature and fluid.

The material groups 1E0 to 6E1 were part of several European national standards and can be described as follows:

- 1E0 unalloyed structural steels without guaranteed thermal-temperature strength, application range $-10\text{ }^{\circ}\text{C}$ to $+100\text{ }^{\circ}\text{C}$;
- 1E1 unalloyed structural steels with thermal-temperature strength according to AD-Merkblatt W1, July 1995, table 4, application range, $-10\text{ }^{\circ}\text{C}$ to $300\text{ }^{\circ}\text{C}$;
- 2E0 unalloyed steels without guaranteed thermal-temperature strength, application range $350\text{ }^{\circ}\text{C}$ up to $400\text{ }^{\circ}\text{C}$;
- 3E0 unalloyed steels with guaranteed thermal-temperature strength, application range up to $400\text{ }^{\circ}\text{C}$;
- 4E0 low alloyed steels with 0,3 % molybdenum;
- 5E0 low alloyed steels with 1 % chromium and 0,5 % molybdenum;
- 6E0 low alloyed steels with 2 % chromium and 1 % molybdenum;
- 6E1 alloy steel with 5 % chromium and 0,5 % molybdenum.

The following groups of materials contain steels with low temperature toughness:

- 7E0 low-temperature-tough fine-grain steel with a minimum yield strength of 315 N/mm^2 at room temperature;
- 7E1 low-temperature-tough fine-grain steel with a minimum yield strength of 380 N/mm^2 at room temperature;
- 7E2 low-temperature high alloy nickel steel;
- 7E3 low temperature steels with strength values for elevated temperatures according to AD-Merkblatt W10, November 1987, table 3a, application range up to $300\text{ }^{\circ}\text{C}$.

The following groups of materials contain creep-resistant fine-grain steels, differentiating only in strength:

- 8E0 yield strength 225 N/mm² min at room temperature;
- 8E1 yield strength 285 N/mm² min at room temperature;
- 8E2 yield strength 315 N/mm² min at room temperature;
- 8E3 yield strength 355 N/mm² min at room temperature;
- 9E0 high-temperature-tough ferritic steel with 12 % chromium, 1 % molybdenum and 0,5 % vanadium.

The following groups contain austenitic stainless steels, with differences in corrosion resistance, weldability and strength, Groups 10E0 up to 12E0 are free of molybdenum, groups 13E0 to 15E0 are alloyed with molybdenum:

- 10E0 extra low carbon steel (ELC-steel);
- 10E1 ELC-steel, nitrogen-alloyed;
- 11E0 standard carbon-content;
- 12E0 alloyed with elements, which form extra stable carbides;
- 13E0 extra low carbon steel with molybdenum;
- 13E1 extra low carbon steel with molybdenum and nitrogen alloyed;
- 14E0 standard carbon-content alloyed with molybdenum;
- 15E0 alloyed with molybdenum and elements, which form extra stable carbides;
- 16E0 austenitic-ferritic steels.

Annex C
(informative)

Approximate masses of flanges and collars

Tables C.1 to C.8 give calculated masses of flanges and ancillary components, which may be used for guidance only.

These calculated masses are based on nominal dimensions given in tables 6 to 13, and on densities of 7,80 g/cm³ for steel materials.

The actual masses may vary from the calculated masses due to dimensional variations within the permitted tolerances given in table 14.

Table C.1 - Masses of flanges PN 2,5

Masses in kilograms

DN	Type 01	Type 05	Type 11
1200	101,5	505,0	77,5
1400	128,0	724,5	89,5
1600	171,0	996,0	117,5
1800	202,5	1305,5	135,0
2000	240,5	1699,5	153,0
2200	-	-	196,0
2400	-	-	213,0
2600	-	-	230,5
2800	-	-	283,5
3000	-	-	304,5
3200	-	-	324,5
3400	-	-	365,5
3600	-	-	410,5
3800	-	-	457,0
4000	-	-	480,5

Table C.2 - Masses of flanges PN 6

Masses in kilograms

DN	Type 01	Type 02	Type 05	Type 11	Type 12	Type 32
10	0,5	0,5	0,5	0,5	0,5	0,5
15	0,5	0,5	0,5	0,5	0,5	0,5
20	0,5	0,57	0,5	0,5	0,5	0,5
25	0,5	0,5	1,0	1,0	1,0	0,5
32	1,0	1,0	1,0	1,0	1,0	0,5
40	1,5	1,5	1,5	1,5	1,5	0,5
50	1,5	1,5	1,5	1,5	1,5	0,5
65	2,0	2,0	2,0	2,0	2,0	0,5
80	3,0	3,0	3,5	3,0	3,0	0,5
100	3,5	3,0	4,0	3,5	3,0	1,0
125	4,5	4,0	6,0	4,5	4,5	1,0
150	5,0	4,5	7,5	5,5	5,0	1,0
200	7,0	6,5	12,5	8,0	7,0	1,5
250	9,0	8,5	18,5	11,5	9,0	2,5
300	12,0	11,5	25,5	15,0	12,0	3,0
350	17,0	16,0	32,0	19,5	-	5,0
400	20,0	19,0	38,5	22,0	-	6,0
450	24,5	23,5	51,0	25,0	-	7,0
500	26,5	25,5	60,03	29,5	-	8,5
600	35,0	33,5	103,0	43,0	-	9,5
700	-	-	178,5	43,5	-	-
800	-	-	252,0	52,0	-	-
900	-	-	335,5	61,5	-	-
1000	-	-	434,5	67,0	-	-
1200	-	-	717,5	105,5	-	-
1400	-	-	1094,0	149,0	-	-
1600	-	-	1545,0	181,5	-	-
1800	-	-	2131,0	235,0	-	-
2000	-	-	2862,0	302,0	-	-
2200	-	-	-	380,5	-	-
2400	-	-	-	463,0	-	-
2600	-	-	-	558,0	-	-
2800	-	-	-	648,5	-	-
3000	-	-	-	736,0	-	-
3200	-	-	-	875,0	-	-
3400	-	-	-	1025,5	-	-
3600	-	-	-	1228,7	-	-

Table C.3 - Masses of flanges PN 10

Masses in kilograms

DN	Type 01	Type 02	Type 04	Type 05	Type 11	Type 12	Type 32	Type 34
200	9,5	9,0	8,0	16,5	11,5	10,5	3,0	5,0
250	12,0	11,5	10,0	24,0	15,5	13,0	3,5	6,5
300	13,5	13,0	11,5	31,0	18,0	15,0	4,0	8,0
350	20,5	19,5	15,0	39,5	24,5	23,5	7,5	12,0
400	27,5	26,5	21,0	49,5	29,5	29,0	9,0	15,0
450	33,5	32,5	26,0	63,0	34,0	33,5	10,5	16,5
500	40,0	39,0	31,0	75,5	39,5	40,5	12,5	20,0
600	54,5	52,5	43,5	124,0	56,0	56,0	14,5	24,0
700	-	-	-	182,5	65,0	-	-	-
800	-	-	-	260,0	87,0	-	-	-
900	-	-	-	344,0	106,0	-	-	-
1000	-	-	-	473,5	123,0	-	-	-
1200	-	-	-	765,0	184,0	-	-	-
1400	-	-	-	-	252,0	-	-	-
1600	-	-	-	-	363,0	-	-	-
1800	-	-	-	-	445,5	-	-	-
2000	-	-	-	-	558,0	-	-	-
2200	-	-	-	-	702,5	-	-	-
2400	-	-	-	-	860,5	-	-	-
2600	-	-	-	-	1010,5	-	-	-
2800	-	-	-	-	1208,0	-	-	-
3000	-	-	-	-	1461,0	-	-	-

Table C.4 - Masses of flanges PN 16

Masses in kilograms

DN	Type 01	Type 02	Type 04	Type 05	Type 11	Type 12	Type 32	Type 34
65	3,0	3,0	3,0	3,5	3,0	3,0	1,0	1,0
80	3,5	3,5	3,0	4,5	4,0	4,0	1,0	1,5
100	4,5	4,5	4,0	5,5	4,5	4,5	1,5	2,0
125	5,5	5,5	4,5	8,0	6,5	6,5	1,5	2,0
150	7,0	7,0	6,0	10,5	7,5	7,5	2,0	3,0
200	9,5	9,5	8,5	16,5	11,0	10,0	3,0	5,0
250	14,0	14,0	12,5	25,0	16,5	14,0	3,5	6,5
300	19,0	18,5	16,5	35,0	22,0	18,0	5,5	10,0
350	28,0	27,5	21,5	48,0	32,0	28,5	10,0	12,5
400	36,0	35,0	27,0	63,5	40,0	36,5	12,5	19,0
450	46,0	45,0	36,5	96,5	54,5	49,5	16,5	25,0
500	64,0	65,0	51,0	133,0	74,0	68,5	21,5	31,5
600	96,0	94,0	78,5	226,5	116,5	107,5	28,5	43,0
700	-	-	-	236,0	87,0	-	-	-
800	-	-	-	325,0	111,0	-	-	-
900	-	-	-	437,5	129,0	-	-	-
1000	-	-	-	602,0	169,0	-	-	-
1200	-	-	-	999,0	251,0	-	-	-
1400	-	-	-	-	329,0	-	-	-
1600	-	-	-	-	476,0	-	-	-
1800	-	-	-	-	582,0	-	-	-
2000	-	-	-	-	720,0	-	-	-

Table C.5 - Masses of flanges PN 25

Masses in kilograms

DN	Type 01	Type 02	Type 04	Type 05	Type 11	Type 12	Type 32	Type 34
200	14,5	14,0	11,5	22,5	17,0	15,0	4,5	7,5
250	20,0	19,5	17,0	33,5	24,0	21,0	5,5	10,0
300	26,5	26,0	22,0	46,5	31,5	28,0	8,5	14,5
350	42,0	41,0	32,0	68,0	48,0	46,5	14,5	22,0
400	55,0	54,0	42,5	89,5	63,0	59,5	18,0	28,5
450	64,5	63,0	50,0	120,0	75,5	71,5	21,0	32,5
500	84,0	82,0	63,5	150,0	96,5	89,5	27,0	43,5
600	127,5	124,5	98,5	244,5	138,6	129,5	34,0	56,5
700	-	-	-	-	143,5	-	-	-
800	-	-	-	-	193,5	-	-	-
900	-	-	-	-	237,0	-	-	-
1000	-	-	-	-	310,5	-	-	-

ZIZI ENGINEERING CO LTD

Table C.6 - Masses of flanges PN 40

Masses in kilograms

DN	Type 01	Type 02	Type 04	Type 05	Type 11	Type 12	Type 32	Type 34
10	0,6	0,5	0,5	1,0	0,5	0,5	0,5	0,5
15	0,5	0,5	0,5	1,0	1,0	0,5	0,5	0,5
20	1,0	1,0	1,0	1,0	1,0	1,0	0,5	0,5
25	1,0	1,0	1,0	1,5	1,0	1,5	0,5	0,5
32	2,0	2,0	1,5	2,0	2,0	2,0	0,5	0,5
40	2,0	2,0	2,0	2,5	2,0	2,0	0,5	0,5
50	2,5	2,5	2,5	3,0	3,0	3,0	0,5	1,0
65	3,5	3,5	3,0	4,5	4,0	4,0	1,0	1,0
80	4,5	4,0	3,5	5,5	5,0	4,5	1,0	1,5
100	6,0	6,0	5,0	7,5	6,5	6,5	1,5	2,5
125	8,0	8,0	7,0	11,0	9,0	8,5	2,0	3,0
150	10,5	10,0	8,5	14,5	11,5	11,0	2,5	4,0
200	18,0	17,5	15,0	29,0	21,0	18,5	5,5	8,5
250	29,5	28,5	24,0	44,5	34,0	28,5	8,0	13,0
300	41,5	40,5	33,5	64,0	47,5	41,5	12,75	20,54
350	62,0	60,74	47,0	89,5	69,0	60,0	19,31	29,50
400	89,5	88,0	69,5	127,0	98,0	83,5	30,38	46,11
450	91,5	90,0	72,5	154,0	105,08	87,5	28,40	48,55
500	120,5	118,0	92,0	188,0	130,5	107,5	35,31	61,70
600	189,5	186,0	149,5	331,0	211,5	176,0	53,32	91,74

Table C.7 - Masses of flanges PN 63

Masses in kilograms

DN	Type 01	Type 05	Type 11	Type 12
50	4,5	5,0	4,5	4,5
65	5,0	6,0	5,5	5,5
80	6,5	7,5	6,5	6,5
100	8,5	10,5	9,5	9,0
125	12,5	16,5	14,5	14,0
150	18,0	24,5	21,5	20,0
200	30,5	40,5	34,0	-
250	43,0	58,0	48,0	-
300	58,5	83,5	67,5	-
350	91,5	116,0	97,5	-
400	121,0	155,5	129,0	-

ZIZI ENGINEERING CO LTD

Table C.8 - Masses of flanges PN 100

Masses in kilograms

DN	Type 01	Type 05	Type 11	Type 12
10	1,0	1,0	1,0	1,0
15	1,0	1,5	1,0	1,0
20	2,0	2,0	2,0	2,0
25	2,5	2,5	2,5	2,5
32	3,0	3,5	3,0	3,0
40	4,0	4,5	4,0	4,0
50	5,5	6,0	6,0	5,5
65	7,0	8,0	7,5	7,0
80	8,0	9,5	9,0	8,0
100	11,0	14,0	13,0	12,0
125	18,5	22,5	21,0	18,5
150	25,0	30,5	28,0	24,5
200	44,5	54,5	50,0	-
250	71,0	87,5	81,0	-
300	107,0	131,5	117,97	-
350	154,0	179,0	167,25	-
400	199,5	-	-	-
500	339,5	-	-	-

Annex D
(informative)

Additional materials

Additional materials may be used as follows:

Table D.1 - Additional materials

Material name	Material number	Material group
C21 ^a	1.0432	1EO
C22.8 ^a	1.0460	3EO
^a According to DIN 2528		

Annex E
(informative)

Determination of p/T ratings for flanges using EN materials

The p/T ratings in tables 15 to 18 were calculated in accordance with the following rules:

a) the ratings are calculated on the basis of strength values specified in European material standards;

b) the pressure is calculated from $PS = PN \left(\frac{R_e}{225} \right)$,

It is limited to $PS \leq PN$:

c) For the value R_e the value R_{eH} or $R_{p0,2}$ and the rupture stress $\sigma_{r/100\ 000}$ is used for all materials. For austenitic materials, the value $R_{p1,0}$ (1 % proof stress) is used for the additional p/T rating tables;

d) to take a product thickness of 40 mm as basis for the calculation (medium flange face thickness);

e) if strength values are not specified for specific temperatures, the p/T ratings shall also not be calculated;

f) if a material group comprises various materials, the material with the lowest strength shall be chosen for calculation. If this is a casting and if its strength values are only slightly below the strength values of a forging or flat product, the strength values of the forging or flat product have been chosen.

NOTE The rules in this annex are given for information only.

Annex F
(informative)

Determination of p/T ratings for flanges using ASTM materials

The p/T ratings in tables 19 and 20 were calculated in accordance with the following rules:

a) the ratings are calculated based on strength values specified in the ASME Boiler and Pressure Vessel Code – Section II. Materials – Part D – Properties 1995 edition July, 1995 – 1996 addenda issued 31st December 1996;

b) the pressure is calculated from: $PS = PN \left(\frac{\text{DesignStrength}}{225} \right)$

c) Design Strengths are determined from:

- yield strengths at temperatures below the creep range;
- 1,5 x maximum allowable stress at temperature for temperatures in the creep range;
- a maximum of 225 N/mm².

NOTE Temperatures in the creep range are defined as:

- above 371 °C (700 °F) for material groups 1C1 to 1C7;
- above 454 °C (850 °F) for material groups 1C9 to 1C14;
- above 510 °C (950 °F) for material groups 2C1 to 2C7

Table F.1 gives the design strengths used to calculate PS.

ZIZI ENGINEERING LTD

Table F.1 - Design Strength for PN Flanges in ASTM Materials

Material group	Maximum allowable temperature TS in °C																					
	RT ^a	50	100	150	200	250	300	350	375	400	425	450	475	500	510	520	530	540	550	575	600	
Design Strength N/mm ²																						
1C1	225,0	225,0	225,0	219,8	213,0	202,7	189,2	179,6	175,0	151,9	125,8	87,6	59,2	38,4	-	-	-	-	-	-	-	-
1C2	225,0	225,0	225,0	225,0	225,0	225,0	209,5	200,1	192,2	151,9	125,8	87,6	59,2	38,4	-	-	-	-	-	-	-	-
1C3	225,0	225,0	219,2	213,6	207,4	197,2	183,2	174,8	169,5	142,7	119,4	86,6	59,2	38,4	-	-	-	-	-	-	-	-
1C4	206,8	202,9	188,3	183,3	177,7	169,3	157,1	150,3	148,1	133,5	113,1	85,6	59,2	38,4	-	-	-	-	-	-	-	-
1C5	225,0	225,0	225,0	217,7	210,3	205,1	199,1	192,9	187,1	167,4	163,7	159,1	146,0	105,3	-	-	-	-	-	-	-	-
1C7	225,0	225,0	225,0	225,0	225,0	225,0	218,6	211,4	204,4	181,0	181,0	177,5	160,8	116,7	95,1	82,8	70,5	59,9	55,1	-	-	-
1C9	225,0	225,0	225,0	225,0	225,0	225,0	218,6	211,4	207,6	203,9	198,9	193,9	154,3	112,2	96,1	85,0	73,8	63,4	55,6	38,5	26,4	26,4
1C10	225,0	225,0	225,0	225,0	225,0	225,0	225,0	225,0	225,0	223,2	219,5	215,2	164,4	125,7	113,8	101,1	88,4	76,5	67,2	46,0	30,1	30,1
1C13	225,0	225,0	225,0	225,0	225,0	225,0	225,0	225,0	224,0	219,0	212,8	204,8	135,5	93,1	82,7	74,5	66,3	58,6	52,7	38,8	27,2	27,2
1C14	225,0	225,0	225,0	225,0	225,0	225,0	225,0	225,0	225,0	225,0	225,0	225,0	196,8	133,1	113,8	100,4	86,9	74,5	65,6	45,7	31,4	31,4
2C1	206,8	199,3	170,3	154,9	143,7	135,4	127,8	123,1	121,6	119,1	116,0	114,1	112,2	110,4	109,6	108,9	108,1	106,8	103,5	91,2	73,8	73,8
2C2	206,8	200,5	175,8	160,4	148,6	139,1	131,7	126,9	124,5	122,7	121,4	120,2	119,5	118,4	117,9	117,5	117,2	116,8	116,4	107,7	87,1	87,1
2C3	172,4	166,5	143,7	130,1	119,5	111,2	105,2	100,2	98,3	96,4	94,5	92,7	-	-	-	-	-	-	-	-	-	-
2C4	206,8	202,1	183,7	170,7	159,6	150,1	142,3	136,4	133,5	131,6	129,7	128,5	127,2	126,0	125,5	125,0	124,5	123,9	122,7	111,9	88,6	88,6
2C5	206,8	203,0	188,0	176,3	165,7	156,9	149,7	144,1	141,9	141,3	140,0	139,4	138,8	138,6	138,6	138,3	138,1	136,9	132,3	114,6	86,6	86,6
2C6	193,1	188,8	172,5	163,2	153,9	146,3	139,3	133,1	130,6	128,1	125,0	122,5	120,0	117,5	116,5	111,4	106,3	101,2	96,0	80,8	63,5	63,5
2C7	193,1	189,0	173,1	163,2	154,5	147,0	140,0	133,6	130,7	128,8	125,7	123,2	120,7	118,2	117,2	113,4	109,5	106,1	104,2	93,6	73,3	73,3

^a -10 °C to 50 °C.

Annex ZA
(informative)

Essential safety requirements

Clauses of this European Standard addressing essential requirements or other provisions of EU Directives

This European Standard has been prepared under a mandate given to CEN by the European Commission and the European Free Trade Association (EFTA) and supports essential requirements of EU Directive 97/23/EC (Pressure Equipment Directive, PED).

WARNING Other requirements and other EU Directives **may** be applicable to the products falling within the scope of this standard.

The following clauses of this standard are likely to support requirements of Directive 97/23/EC.

Compliance with the clauses of this standard provides one means of conforming with the specific essential requirements of the Directive concerned and associated EFTA regulations.

Table ZA.1 - Correspondence between this European Standard and Directive 97/23/EC

Clause/ subclause of this European Standard	Essential requirements (ER's) of Directive 97/23/EC		Qualifying remarks/ notes
5.1	Annex 1, Clause 4	Materials: Materials for pressure equipment to be suitable during lifetime - unless replacement is foreseen.	-
	Annex 1, Clause 4.1a)	Materials for pressurized parts to have appropriate properties for all operating and test conditions: - to be sufficiently ductile and tough; - characteristics of material to comply with ESR's at 7.5 - to be selected in order to prevent brittle-type fracture, or appropriate measures to be taken.	-

(continued)

Table ZA.1 (concluded)

Clause/ subclause of this European Standard	Essential requirements (ER's) of Directive 97/23/EC		Qualifying remarks/ notes
5.5	Annex 1, Clause 2	Design	
	Annex 1, Clause 2.1	To be designed to ensure safety throughout intended life - to incorporate appropriate safety coefficients.	-
	Annex 1, Clause 2.2	To be designed for adequate strength.	-
	Annex 1, Clause 2.2.1	To be designed for loadings appropriate to its intended use.	
	Annex 1, Clause 2.2.2	To be designed for appropriate strength based on a calculation method.	-
	Annex 1, Clause 2.2.3(a)	Requirements to be met by applying one of the following methods - design by formula.	-
	Annex 1, Clause 2.2.3(b)	Design calculations to establish the resistance of equipment, in particular - account to be taken of combinations of temperature & pressure; - maximum stresses & peak stresses to be within safe limits.	-
	Annex 1, Clause 7	Specific quantitative requirements for certain pressure equipment.	-
5.10	Annex 1, Clause 3.1.5	Traceability Materials making up component parts to be identified by suitable means from receipt, through production, up to final test.	-

Bibliography

EN 287-1, *Approval testing of welders; fusion welding - Part 1: Steels*

EN 288-1, *Specification and qualification of welding procedures for metallic materials - Part 1: General rules for fusion welding*

EN 1514-1, *Flanges and their joints - Dimensions of gaskets for PN-designated flanges - Part 1: Non metallic flat gaskets with or without inserts*

EN 1514-2, *Flanges and their joints - Dimensions of gaskets for PN-designated flanges - Part 2: Spiral wound gaskets for use with steel flanges*

EN 1514-3, *Flanges and their joints - Dimensions of gaskets for PN-designated flanges - Part 3: Non-metallic PTFE envelope gaskets*

EN 1514-4, *Flanges and their joints - Dimensions of gaskets for PN-designated flanges - Part 4: Corrugated, flat or grooved metallic and filled metallic gaskets for use with steel flanges*

EN 1515-1, *Flanges and their joints - Bolting - Part 1: Selection of bolting*

EN 1515-2:1994, *Flanges and their joints - Bolting - Part 2: Combination of flange materials and bolting materials for steel flanges - PN designated*

EN 10204, *Metallic products - Type of inspection documents (includes Amendment A1:1995)*

EN ISO 4287, *Geometrical product specification (GPS) – Surface texture: Profile method – Terms, definitions and surface texture parameters (ISO 4287:1997)*

ISO 4200, *Plain end steel tubes, welded and seamless; General tables dimensions and masses per unit length*

DIN 2528, *Flanges - Steel flanges ready for use – Materials*

AD Merkblatt W10: 1987, *Materials for low temperature application – Ferritic materials*

AD Merkblatt W1: 1995, *Hot rolled products in unalloyed and alloyed steels*

ASME, *Boiler and Pressure Vessel Code – Section II. Materials – Part D – Properties 1995 edition July, 1995 – 1996 addenda issued 31 December 1996*